

SMARTER WATER FOR A
SMARTER HOME



01

PUMPS

HLVSP VARIABLE SPEED PUMP

LASWIM creatively combines the most advanced technology (Permanent magnet brushless DC motor) with the professionally designed hydraulic structure of the swimming pool pump to create a more usable, quieter, more intelligent, more efficient and less expensive variable speed pool pumps.



Material:

- Pump housing: PP+35%GF
- Filter basket: PP
- Shaft: SS316
- Mechanical Seal: stationary face-SIC, rotating face-Graphite, seal bellows-NBR, Spring- 316L
- Impeller: PPO+30% GF
- Diffuser: PPO+30% GF



Simple and fast operation

- Comes with 4 pre-set most commonly used working modes.
- One-button tap, directly to the desired function.
- Stepless variable speed technology, 1000-2900 rpm can be adjusted freely to meet various professional needs.

Quiet

- HLVSP pumps reduce operating noise, featuring an upgraded motor drive that delivers quieter high-speed operation.
- Sound level 45dB in 1 meter at the speed of 1400rpm.

Intelligent

- All operations can be completed via mobile APP.
- Support centralized management of multiple devices, you can check the status of the water pump in real time, customize functions and the protection against accidental power failure.
- Support OTA upgrade, support firmware update.

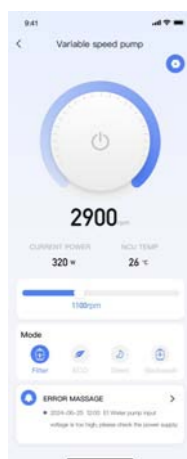

DOWNLOAD THE APP "TUYA" FROM GOOGLE PLAY OR APP STORE.

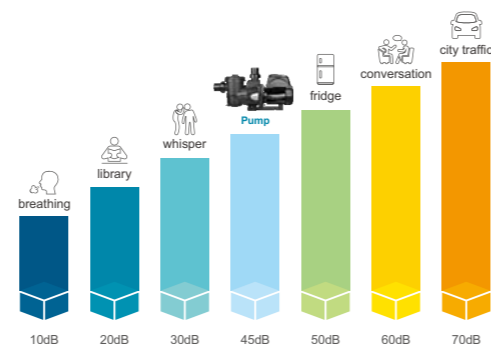
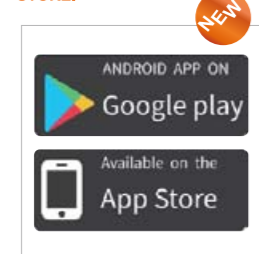

Energy saving

- HLVSP pumps reduce the energy by up to 90%, saving up to 12,614kWh(2hp pump runs in 365days).

High energy efficiency

- High efficiency motor IE4.
- Ambient temperature: up to 45°C (113°F).
- Insulation Class: F.
- IP55 waterproof standard.
- Liquid temperature:5~50°C (41~122°F).
- Maximum working pressure: 3.5bar.

QH.Curve of HLVSP100QW

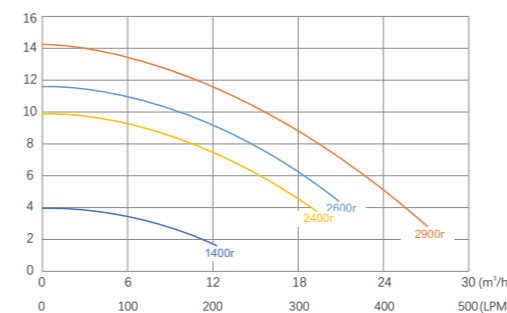

QH.Curve of HLVSP150QW

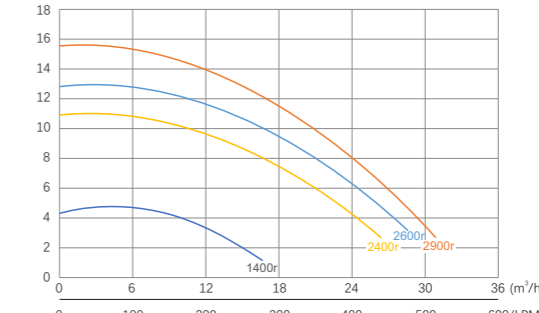

QH.Curve of HLVSP200QW

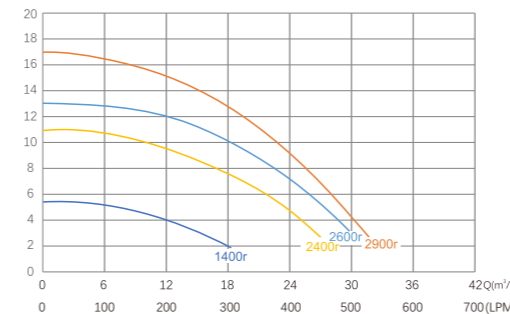

QH.Curve of HLVSP100QWU

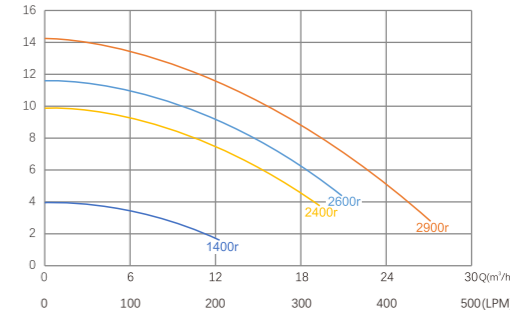

QH.Curve of HLVSP150QWU

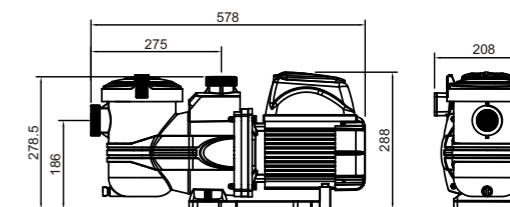
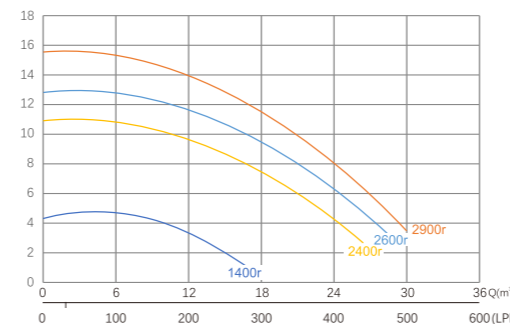

Model	Output power (P2)		Rated power supply	Max. current (A)	RPM	Q-max (m³/h)	H-max (m)	Circulation Flow		Connection Size	Packing size (mm)
	Horse power (HP)	Rated power (kW)						Flow at 8 m (m³/h)	Flow at 10 m (m³/h)		
WL-HLVSP100QW	1	0.75	220V-240V; 50Hz/60Hz	4.1	1000-2900	27	14.5	20	16	2" 63mm	620×280×380
WL-HLVSP150QW	1.5	1.1		5.5		30	16	24	21		
WL-HLVSP200QW	2	1.5		7		33	17	26	23		
WL-HLVSP100QWU	1	0.75	110-120V; 50/60Hz	8		27	14.5	20	16		
WL-HLVSP150QWU	1.5	1.1		11	30	16	24	21			

HV2 INTELLIGENT VARIABLE SPEED PUMP

WL-HV2 intelligent variable speed pump is an innovative product that combines high performance and reliability. It features ultra-quiet running, optimal speed and flow rate, which improves the efficiency of the pump, reduces maintenance and operation costs, and creates a sustainable, environmentally friendly and energy-saving solution for swimming pool water circulation.



Product Material

- Pump body:PP+35%GF
- Seal plate:PP+35%GF
- Diffuser:PPO+30%GF
- Impeller:PPO+30%GF+copper core
- Motor shaft:SS316
- Basket:PP
- Max. Working pressure:3.5bar
- Pump base:PP+35%GF
- Mechanical seal:Stationary face-SIC,rotating face-Graphite,seal bellows-NBR, Spring-316L
- Self-priming:Up to 3M
- Protection class:IP55
- Liquid Temperature:5-50°C(41~122°F)
- Ambient Temperature:5-50°C(41~122°F)

Energy saving

- HV2 pumps reduce the energy by up to 90%, saving up to 12,614kWh(2hp pump runs in 365 days).

Excellent hydraulic performance

- The advanced hydraulic design enables the HV2 pump to achieve a self-priming capability up to 3 meters, high head and massive flow.

Intelligent and Smart Control

- Wi-Fi connectivity, mobile App control, OTA upgrade.
- RS485 communication port, passive dry contact interface.
- Built-in one-operate-one-standby function. Supporting linkage with pumps, and meeting the design specifications for one-operate-one-standby. Equipped with fault alarm and protection, it automatically switches to the standby pump in case of abnormal conditions, ensuring stable operation around the clock.
- Download the App "TUYA SMART" from Google play or App Store.

Fully programmable and up to 4 pre-set speeds and timer functions.

Motor drive includes built-in protection

- Temperature sensor for high temperature protection and anti-freeze protection.
- Pressure probe for monitoring water supply pressure and flow rate changes.
- Dry burn protection.



IE4 Motor

- The IE4 high-efficiency motor is capable of long-term, stable, and efficient operation, delivering greater flow rates and higher head pressures, the overall performance is truly outstanding.

Quite Running

- System sound level 45dB in 1 meter at the speed of 1500rpm.



Digital control interface that can be mounted on the pump in 3 different orientations.

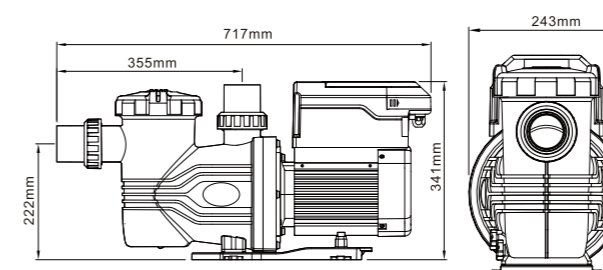
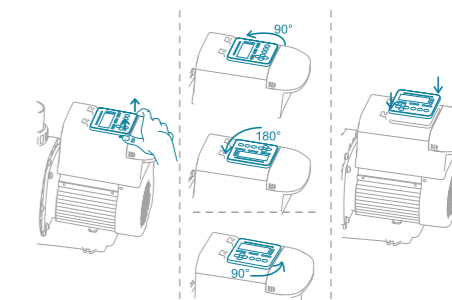

HV2-100 Q-H curve

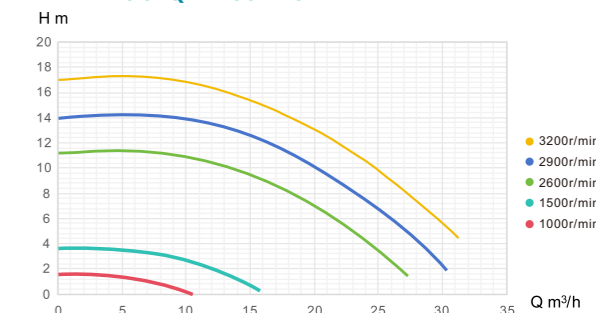

HV2-150 Q-H curve

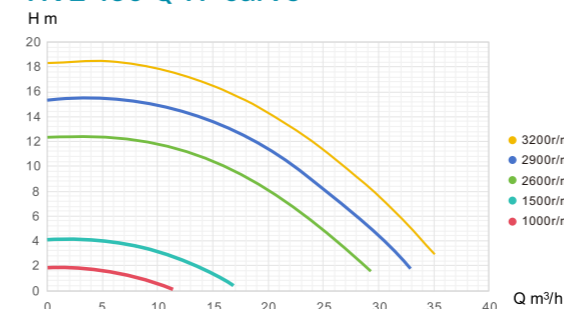

HV2-200 Q-H curve

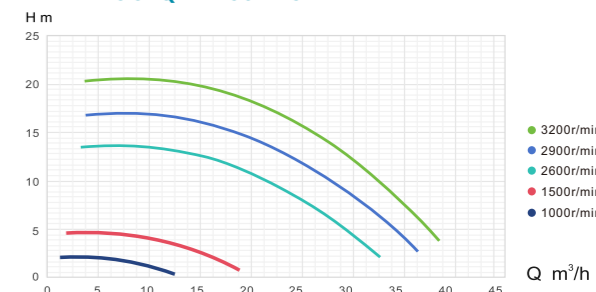

Model	Input Power (P1)	Rated output horse power(P2)	Rated power supply	Max. Current (A)	RPM	Motor energy efficiency Class
WL-HV2-100	1000W	1HP	220-240V 50/60Hz	4.7	1000-3200	IE4
WL-HV2-150	1300W	1.5HP		6		IE4
WL-HV2-200	1650W	2HP		7		IE3

Model	Q-max (m³/h)	H-max (m)	Head		Connection size	noise (dB)
			10m	8m		
			Flow Rate(m³/h) @ 2900rpm			
WL-HV2-100	31	16.9	20	23	2" 63mm	<58
WL-HV2-150	35	18	22.5	25.5		<60
WL-HV2-200	40	20	28	30		<64

BDP SERIES HIGH PERFORMANCE PUMP

BDP series high performance plastic centrifugal pump delivers high flow rates. It is designed for the commercial swimming pool, spa, waterfall and water features to achieve the maximum working efficiency with the lowest noise. Suitable for operation with salt chlorinators and sea water.

Highlight Features:

- IPX5 waterproof standard.
- Asynchronous, two poles.
- Insulation class: F.
- The advanced diffuser and high efficiency turbine maximize water flow and energy efficiency while minimizing turbulence and noise.
- Self-priming up to 3M above water level.
- Built-in thermal protection and overload protection.
- The oversized pre-filter basket(5L) extends the interval between cleanings.
- Liquid Temperature: 5~50°C(41~122°F)
- Ambient Temperature: up to 45°C(113°F)



CE



High Performance



Self-priming Up To 3m

Key Features:

The advanced diffuser and high efficiency turbine maximize water flow and energy efficiency while minimizing turbulence and noise.



Material:

- Pump Housing: PP+35% GF
- Filter basket: PP
- Shaft: SS316L
- Mechanical Seal: stationary face-SIC, rotating face-Graphite, seal bellows-NBR, Spring-316L
- Impeller: PPO+30% GF
- Diffuser: PPO+30% GF
- Pump base: PP+30% GF

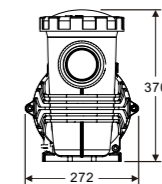
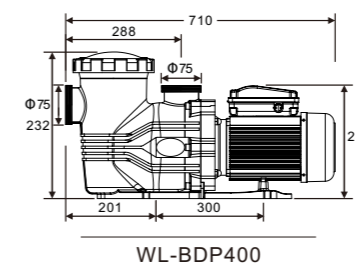
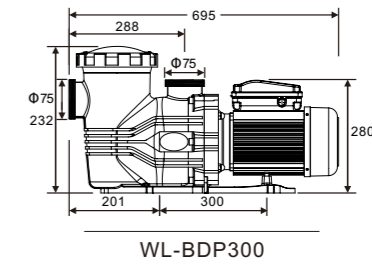
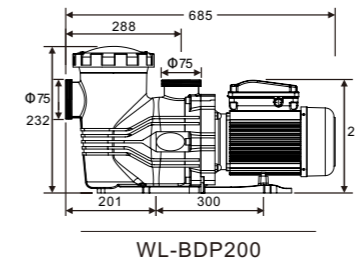

QH.Curve of The Pump

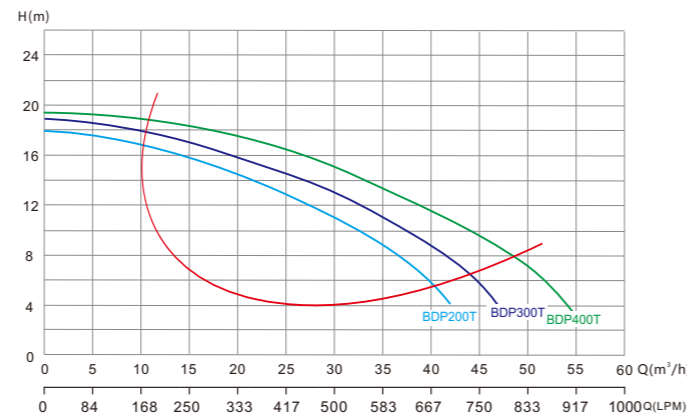
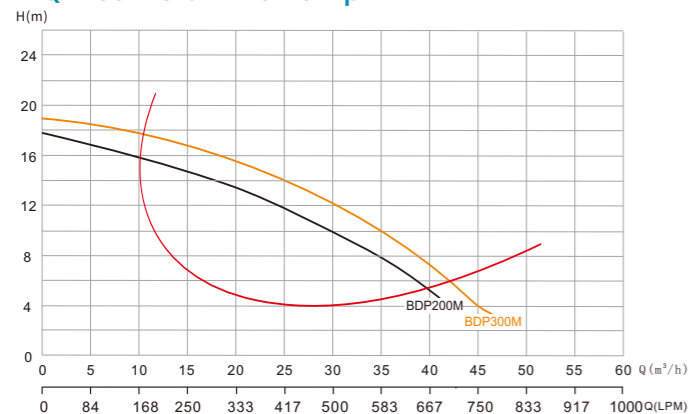

Model	Q-max (m³/h)	H-max (m)	Horsepower (HP)	Phase	Rated Power (kW)	Voltage (V)	Current (AMP)	Connection Size
WL-BDP200M	42	18	2	1	1.8	220	8.8	2" 63mm
WL-BDP300M	45	18.5	3	1	2.2	220	10.6	2.5" 75mm
WL-BDP200T	43	18.5	2	3	1.8	380	3.2	2" 63mm
WL-BDP300T	48	19	3	3	2.2	380	3.8	2.5" 75mm
WL-BDP400T	55	19.5	4	3	2.7	380	4.6	2.5" 75mm

HLLF SERIES PUMP

Material:

- Pump housing: PP+35%GF
- Filter basket: PP
- Shaft: SS316
- Bearing: NSK
- Mechanical seal: Carbon+Resin-Ceramics (Carbon, Ceramics, SS304,NBR)
- Impeller: Noryl+30% Fiberglass
- Diffuser and pump base: PP+35% Fiberglass

Features:

- The inlet and outlet of this series comes with an external thread, which can be used to connect to metric or imperial pipes.
- The pump has excellent performance and reliable quality, which can bear 25000 times of impact test.
- Low noise: 0.75 HP can lower than 65 dB.
- Liquid Temperature: 5 ~ 50 °C (41 ~ 122 °F).
- Ambient Temperature: up to 45°C (113°F).
- Maximum working pressure: 2.5 bar.
- IPX5 waterproof standard
- Class I protection against electric shock.
- Thermal protection included.
- Motor: 3000r.p.m.
- Single phase:220V/50Hz
- 220V/60Hz, 380V/50Hz are available on request



0.75HP-1.5HP



2.0HP-3.0HP



QH.Curve of The Pump:

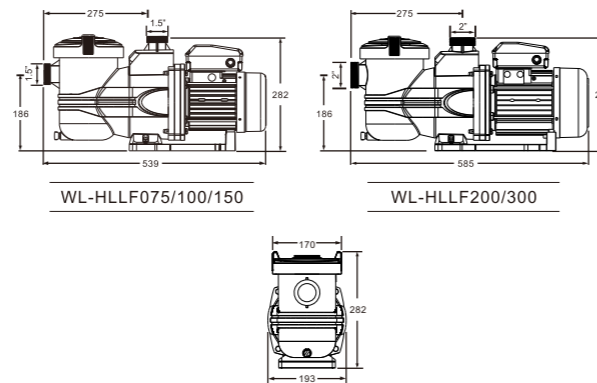
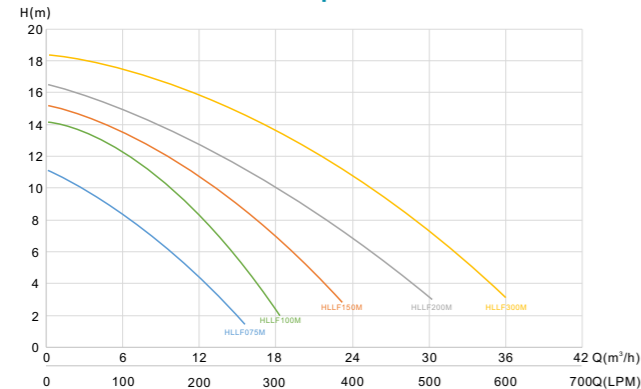

Model	Q-max (m³/h)	H-max (m)	Horsepower (HP)	Rated Power (kW)	Phase	Voltage (V)	Connection size
WL-HLLF075M	14.8	11.1	0.75	0.6	1	220	1.5" 50mm
WL-HLLF100M	17.4	14.1	1	0.8	1	220	1.5" 50mm
WL-HLLF150M	22.1	15.1	1.5	1.1	1	220	1.5" 50mm
WL-HLLF200M	30.2	16.4	2	1.6	1	220	2" 63mm
WL-HLLF300M	36	18.2	3	2.2	1	220	2" 63mm
WL-HLLF100T	15.8	13.9	1	0.8	3	380	1.5" 50mm
WL-HLLF150T	22.7	15.2	1.5	1.1	3	380	1.5" 50mm
WL-HLLF200T	33.1	16.9	2	1.6	3	380	2" 63mm
WL-HLLF300T	39.8	18.2	3	2.2	3	380	2" 63mm

ECP SERIES PUMP



ECP series is a new silent and high-performance swimming pool centrifugal pump, suitable for small and medium-sized water application. With the independently innovative hydraulic structure design, ECP series pool pump improves the efficiency and performance, greatly reduces the vibration and operating noise as well.

Highlight features:

- Asynchronous motor.
- The innovative design on impeller and diffuser makes the higher pump performance and reduces the vibration and noise.
- Protection standard: IP55.
- Insulation class: F.
- Self-priming up to 3m.
- Noise: ≤ 61dB.
- Built-in thermal protection and overload protection (for single phase pump).
- Standard port size: 2", 63mm.
- Motor: 2900r.p.m
- Liquid temperature: 5-50°C(41~122°F).
- Ambient temperature: 5-50°C(41~122°F).
- Maximum working pressure: 3.5bar.

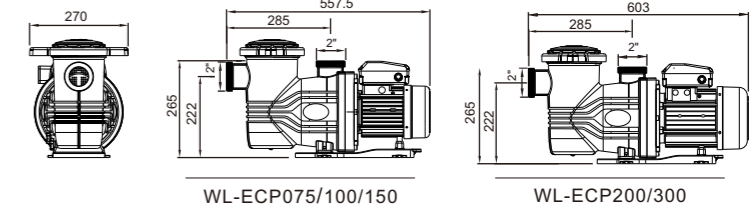

Material:

- Pump housing: PP+35%GF
- Seal plate: PPO+30%GF
- Diffuser: PPO+30%GF
- Impeller: PPO+30%GF+ Copper core
- Motor shaft: SS316
- Filter basket: PP
- Pump base: PP+35%GF
- Mechanical seal: stationary face-SIC, rotating face-Graphite, seal bellows-NBR, Spring-316L.

QH.Curve of The Pump:

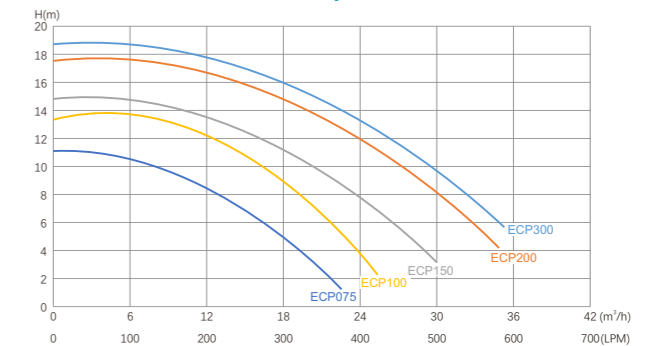

Model	Q-max (m³/h)	H-max (m)	Circulation Flow		Horse Power (HP)	Rated Power (kW)	Voltage (V)	Phase	Connection Size	Noise (dB)
			Flow at 8 m (m³/h)	Flow at 10 m (m³/h)						
WL-ECP075M	22	11.5	13	8	0.75	0.6	220	1	2" 63mm	52.1
WL-ECP100M	24	14	19.5	16.5	1	0.8	220	1	2" 63mm	54.4
WL-ECP150M	30	15	23.5	21.5	1.5	1.1	220	1	2" 63mm	56.9
WL-ECP200M	35	18	30	27	2.0	1.6	220	1	2" 63mm	59.6
WL-ECP300M	36	19	32.5	29.5	3.0	2.2	220	1	2" 63mm	61
WL-ECP100T	24	14	19.5	16.5	1	0.8	380	3	2" 63mm	54.4
WL-ECP150T	30	15	23.5	21.5	1.5	1.1	380	3	2" 63mm	56.9
WL-ECP200T	35	18	30	27	2.0	1.6	380	3	2" 63mm	59.6
WL-ECP300T	36	19	32.5	29.5	3.0	2.2	380	3	2" 63mm	61

XK SERIES POOL PUMP

Introduction

Combining powerful performance with exceptional durability, this pump meets the diverse needs of different customer groups. The motor features mechanical seals, ensuring stable sealing performance and extended service life during prolonged operation, effectively preventing water leakage. The motor is completely isolated from water, making it safe and reliable.

Application Scenarios

This pump is suitable for water circulation and filtration in various applications including swimming pools, water features, hot springs, saunas, bathing pools, aquaculture, etc.



CE

WL-XK554~WL-XK2204

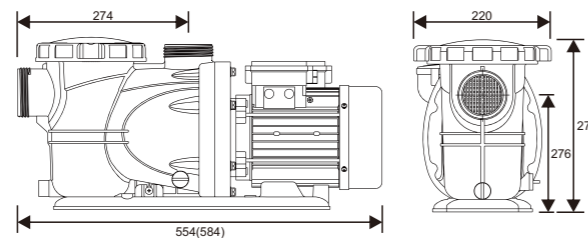

QH.Curve of The Pump

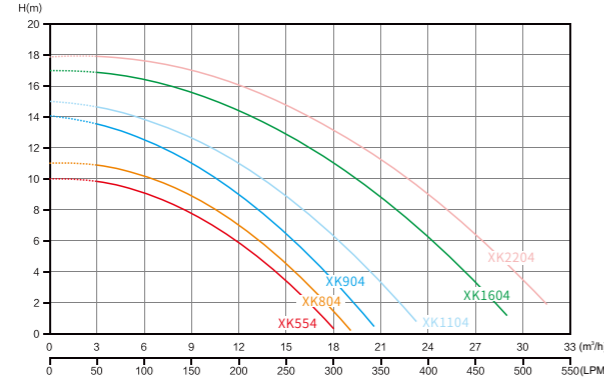

Model	Q-max (m³/h)	H-max (m)	HorsePower (HP)	RatedPower (kW)	Phase	Voltage (V)	Connection Size
WL-XK554	17	10	0.8	0.60	1	220-240	1.5" 50mm
WL-XK804	19	11	1.1	0.80	1	220-240	1.5" 50mm
WL-XK904	20	14	1.2	0.90	1	220-240	1.5" 50mm
WL-XK1104	22	15	1.5	1.10	1	220-240	1.5" 50mm
WL-XK1604	27	17	2.2	1.60	1	220-240	1.5" 50mm
WL-XK2204	31	18	3	2.20	1	220-240	1.5" 50mm

ESP SERIES PUMP



CE

LASWIM ESP series pump is a circulation pump for pools with high reliability and performance, which makes the pump more recognized in the market. Mechanical seal adopts ceramic carbon material, which is resistant to high temperature and dry grinding. With 25,000 strict life-span tests and powerful impact tests, this pump is highly recommended for its great performance and reliable quality.

Features:

- The inlet or outlet of the pump with an external thread, which can connect with metric or imperial pipes.
- Low noise: It can lower than 67 dB.
- Thermal protection included
- Liquid Temperature: 5~ 50 °C (41 ~ 122 °F).
- Ambient Temperature: up to 40°C (104°F).
- IPX5 Waterproof standard.
- The pump can bear 25000 times of impact test, excellent performance and reliable quality.
- Single phase: 220V/50Hz
220V/60Hz is available on request

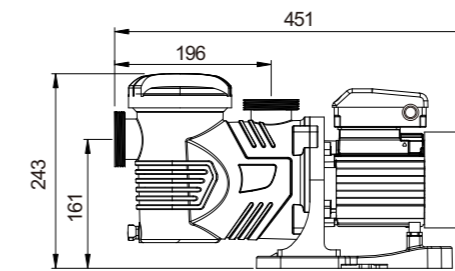

WL-ESP033/050/075

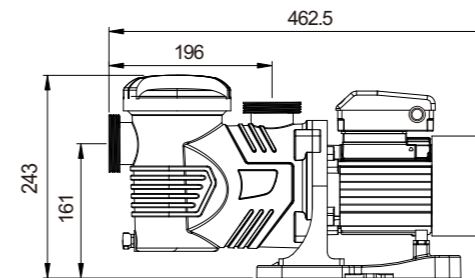

WL-ESP100/120

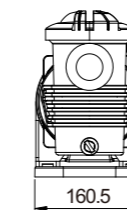

QH.Curve of The Pump:

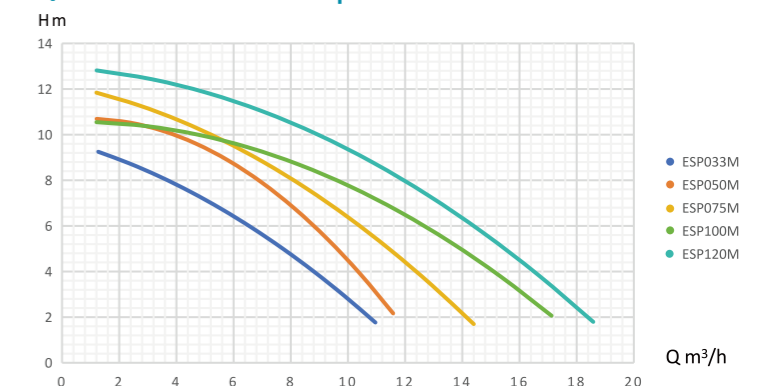

Model	Q-max (m³/h)	H-max (m)	Horsepower (HP)	Rated Power (kW)	Phase	Voltage (V)	Connection size
WL-ESP033M	11	9	0.33	0.26	1	220	1.5" 50mm
WL-ESP050M	11.5	10.5	0.5	0.37	1	220	1.5" 50mm
WL-ESP075M	14.5	12	0.75	0.55	1	220	1.5" 50mm
WL-ESP100M	17	10.5	1.0	0.75	1	220	1.5" 50mm
WL-ESP120M	19	13	1.2	0.9	1	220	1.5" 50mm

BHP/BHP-E SERIES PUMP

BHP/BHP-E heavy-duty pumps deliver high flow and high performance. It's designed for commercial swimming pools. Unique large diffuser and maximum performance impeller with high-performance motor maximize energy efficiency.

Features:

- The inlet or outlet port can connect with metric or imperial pipes.
- The pump has excellent performance and reliable quality, which can bear 25000 times of impact test.
- Liquid Temperature: 5~ 50 °C (41 ~ 122 °F).
- Ambient Temperature: up to 45°C (113°F).
- Maximum working pressure: 2.5 bar.
- IPX5 waterproof standard
- Class I protection against electric shock.
- Thermal protection included.
- The motor is painted fluoride-resistant acid corrosion protective coating, resists chemical and marine corrosion. (for BHP-E series pump)
- Motor: 3000r.p.m.
- 50Hz or 60Hz is available for different necessities.



CE

Material:

- Pump Housing: PP+35%GF
- Filter Basket: PP
- Shaft: SS304
- SS316 (For seawater pump BHP-E series)
- Bearing: NSK
- Mechanical seal: Carbon+Resin-Ceramics (Carbon, Ceramics, SS304, EPDM)
- SS316+EPDM(Sealsbellows)+SIC+ Graphite (For seawater pump BHP-Eseries)
- Impeller: Noryl+30%GF
- Diffuser: Noryl+30%GF
- Pump Base: PP+35%GF

QH.Curve of The Pump

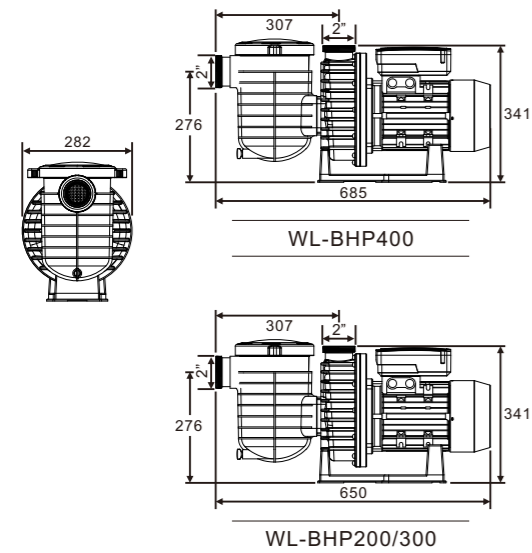
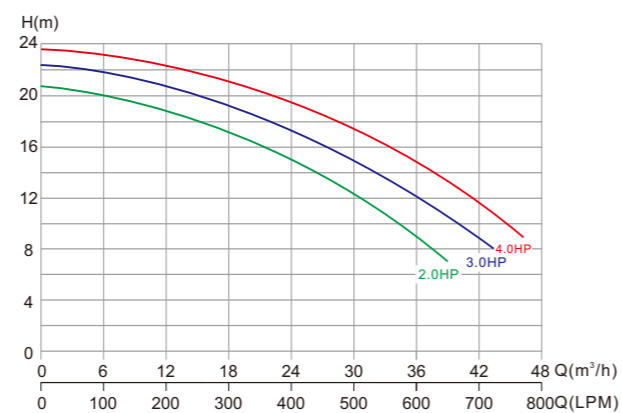

Model	Q-max (m³/h)	H-max (m)	Horsepower (HP)	Rated Power (kW)	Phase	Voltage (V)	Connection size
WL-BHP200M WL-BHP-E200M	38	20	2.0	1.5	1	220	2" 63mm
WL-BHP300M WL-BHP-E300M	42	21	3.0	2.2	1	220	2" 63mm
WL-BHP200T WL-BHP-E200T	38	20	2.0	1.5	3	380	2" 63mm
WL-BHP300T WL-BHP-E300T	42	21	3.0	2.2	3	380	2" 63mm
WL-BHP400T WL-BHP-E400T	45	22	4.0	3.0	3	380	2" 63mm



CE

WL-KP256~WL-KP856



CE

WL-KP1106~WL-KP2206

WL-KP series are used for water circulation in all kinds of small domestic swimming pools. Slightly dirty water with solids in suspension can be perfectly filtered.

Features:

- Liquid Temperature: 5~ 50 °C (41 ~ 122 °F).
- Ambient Temperature: up to 40 °C (104 °F).
- Maximum working pressure: 3.0 bar.
- IPX5 waterproof standard.
- Insulation Class: F.
- Thermal protection included.
- Single phase: 220V/50Hz.
- 220V/60Hz, 110V/60Hz; 380V/50Hz(P≥450W) are available on request.
- **Max.Suction:3M(P≥600W)**

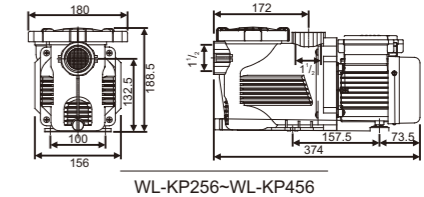

WL-KP256~WL-KP456

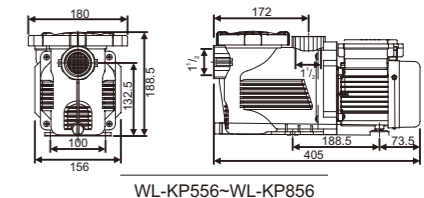

WL-KP556~WL-KP856

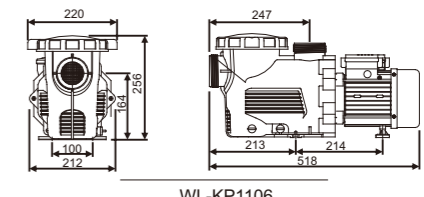

WL-KP1106

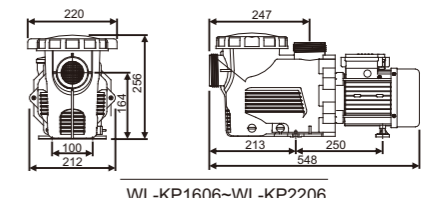

WL-KP1606~WL-KP2206

QH.Curve of The Pump

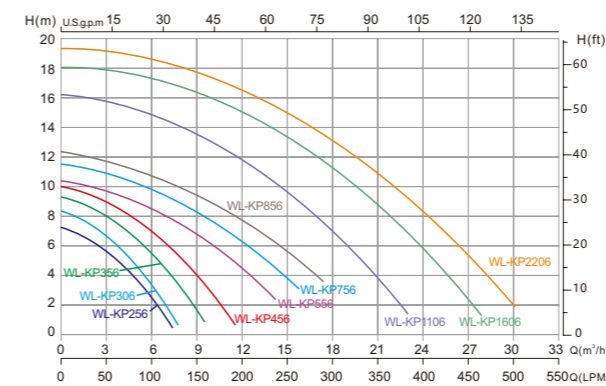

Model	Q-max (m³/h)	H-max (m)	Horsepower (HP)	Rated Power (kW)	Phase	Voltage (V)	Connection Size
WL-KP256	7.5	7	0.33	0.25	1	220	1.5" 50mm
WL-KP306	7.5	8.5	0.4	0.3	1	220	1.5" 50mm
WL-KP356	9.6	9.5	0.5	0.35	1	220	1.5" 50mm
WL-KP456	11.1	10	0.6	0.45	1	220	1.5" 50mm
WL-KP556	14.1	12	0.75	0.55	1	220	1.5" 50mm
WL-KP756	15.6	12.5	1.0	0.75	1	220	1.5" 50mm
WL-KP856	16.5	12.5	1.2	0.85	1	220	1.5" 50mm
WL-KP1106	22.5	16	1.5	1.10	1	220	1.5" 50mm or 2" 63mm
WL-KP1606	27.9	18	2.0	1.60	1	220	1.5" 50mm or 2" 63mm
WL-KP2206	30.9	19.5	3.0	2.20	1	220	1.5" 50mm or 2" 63mm

STP SERIES PUMP

Features:

- Motor and water are completely separated.
- Total electrical separation.
- Pump housing, pump cover & impeller are made of high reinforced plastic.
- Quick record could be used with the inlet & outlet.

Operation conditions:

- Liquid Temperature: 5~ 50 °C (41 ~ 122 °F).
- Ambient Temperature: up to 50°C (122°F).
- Maximum working pressure: 3.0 bar.

Applications:

Jet pump for jetted bath tubs, spa pools, swimming pools, massage stations and cleaning system.



0.35HP-1.2HP



1.5HP-3.0HP

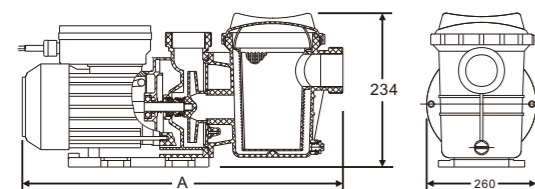

WL-STP35~WL-STP120

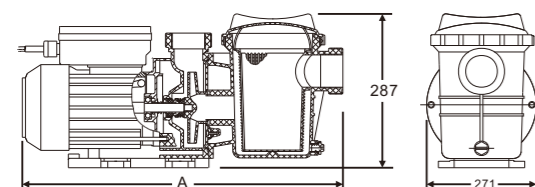

WL-STP150~WL-STP300

QH.Curve of The Pump

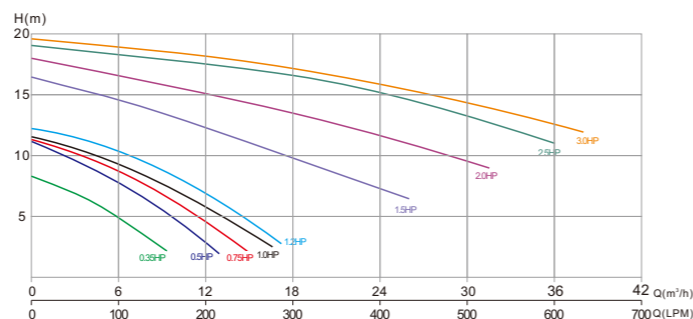

Model	Q-max (m³/h)	H-max (m)	Horsepower (HP)	Rated Power (kW)	Phase	Voltage (V)	Connection size	A Length (mm)
WL-STP35	9.6	8	0.35	0.26	1	220	1.5" or 50mm	443
WL-STP50	12.6	11	0.5	0.37	1	220	1.5" or 50mm	443
WL-STP75	14.4	10.5	0.75	0.56	1	220	1.5" or 50mm	465
WL-STP100	16.5	11	1.0	0.75	1	220	1.5" or 50mm	465
WL-STP120	18	13	1.2	0.9	1	220	1.5" or 50mm	465
WL-STP150	25.8	16.5	1.5	1.1	1	220	2" or 63mm	573
WL-STP200	31.2	18	2.0	1.5	1	220	2" or 63mm	573
WL-STP250	36	19	2.5	1.87	1	220	2" or 63mm	573
WL-STP300	38.1	19.5	3.0	2.25	1	220	2" or 63mm	598
WL-STP300	38.1	19.5	3.0	2.25	3	380	2" or 63mm	598

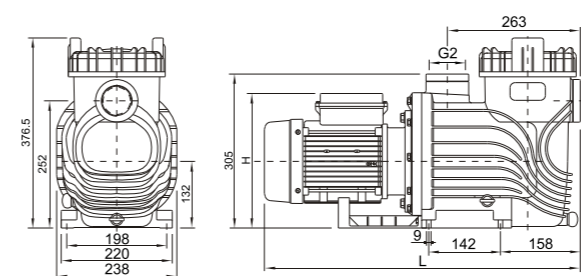

LAKP SERIES PUMP

Featuring a sleek, unique design, the LAKP series high-performance pump combines reinforced engineering plastic housing with Stainless Steel reinforced ports for extra strength. Equipped with a 3.2L large basket for easy maintenance and self-priming capability (max. 2.5m suction). With AC-structure bearings to minimize noise, it delivers long-lasting, whisper-quiet operation and perfect for spas, commercial pools, and water parks.

Features:

- Self-priming up to 2.5m
- Protection standard: IP55
- Insulation class: F
- Liquid temperature: 0-75°C (0~167°F)
- Ambient temperature: ≤50°C (122°F)
- Max. Working pressure: 10.0bar

QH.Curve of The Pump

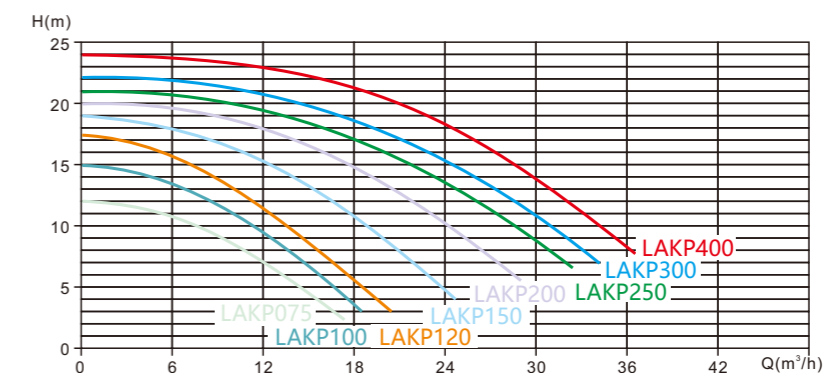

Model	Q-Max (m³/h)	H-Max (m)	Rated power supply	Input power		Current (A)	Length (mm)	Height (mm)	Connection size	Weight (kg)	Packing size (mm)
				kW	HP						
WL-LAKP075MT	17.4	12	M: 220V/50Hz T: 380V/50Hz	0.55	0.75	3.2	575	238	1.5" or 50mm	16	615 X 270 X 440
WL-LAKP100MT	18.6	15		0.75	1.0	3.8	575	238	1.5" or 50mm	16.5	615 X 270 X 440
WL-LAKP120MT	20.4	17.5		0.9	1.2	4.6	575	238	1.5" or 50mm	17	615 X 270 X 440
WL-LAKP150MT	24.6	19		1.1	1.5	5.2	594.5	243	2" or 63mm	19	635 X 270 X 440
WL-LAKP200MT	28.8	20		1.5	2.0	7.0	594.5	246	2" or 63mm	20.3	635 X 270 X 440
WL-LAKP250MT	32.4	21		1.85	2.5	8.6	594.5	258	2" or 63mm	22.4	635 X 270 X 440
WL-LAKP300MT	34.2	22		2.2	3.0	10	594.5	258	2" or 63mm	22.4	635 X 270 X 440
WL-LAKP400MT	36.6	24		3.0	4.0	14	626	267	2" or 63mm	26.2	665 X 270 X 440

KBP SERIES SEAWATER PUMP

KBP seawater pump is a series of sturdy and durable pump with high head and sufficient flow. The body has strong sealing, corrosion resistance and pressure resistance. Suitable for all kinds of aquaculture ponds and seawater ponds.

Features:

- Protection: IP55.
- Large flow rate.
- Low noise level.
- Max. working pressure: 6.0bar
- Shaft: Stainless steel 316.
- Mechanical seal: Graphite / Ceramic seal.

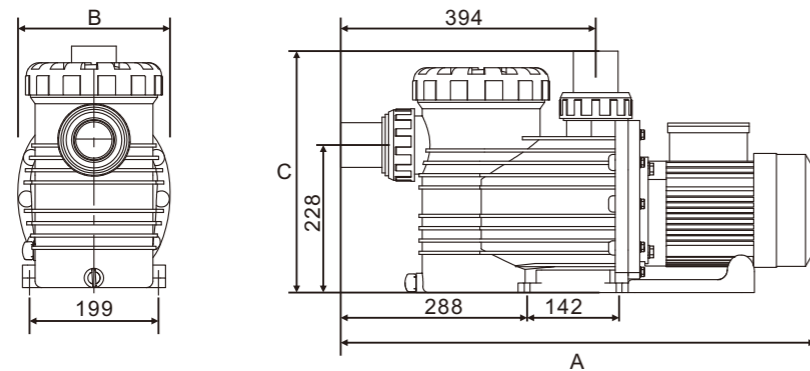

QH.Curve of The Pump

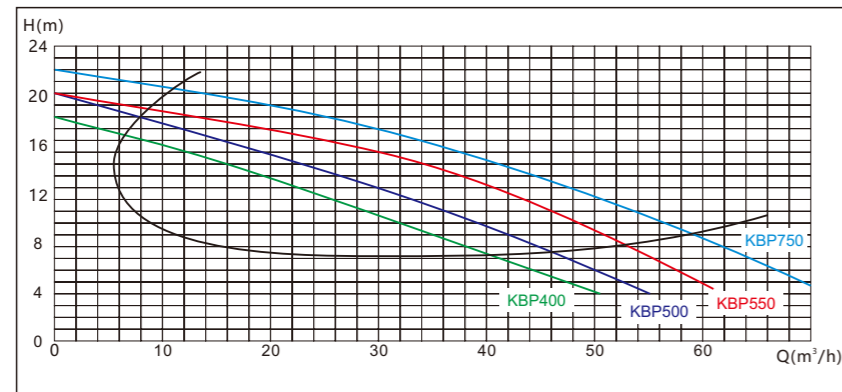

Model	Q-Max (m³/h)	H-Max (m)	Rated power supply (V/Hz)	Input power		A Length (mm)	B Width (mm)	C Height (mm)	Connection size	Weight (kg)	Packing size (mm)
				kW	HP						
WL-KBP400	50	18	380/50	3	4	750	221	373	2"/63mm	30	775×315×450
WL-KBP500	55	20	380/50	3.7	5	750	221	373	2"/63mm	30	
WL-KBP550	60	20	380/50	4	5.5	770	221	373	2.5"/75mm 3"/90mm	33	830×315×440
WL-KBP750	70	22	380/50	5.5	7.5	780	221	373	2.5"/75mm 3"/90mm	37	



SLP SERIES PUMP

Designed for large water parks, aquariums, and hot spring filtration, SLP series heavy-duty pump features an integrated plastic baseplate for easy installation. The high efficiency motor ensures energy savings and long service life. Corrosion-resistant and low-maintenance, it delivers reliable performance in commercial water circulation systems.

Features:

- Protection standard: IP55
- Insulation class: F
- Liquid temperature: 0-75°C (0~167°F)
- Ambient temperature: < 50°C (122°F)
- Max. Working pressure: 7.0bar

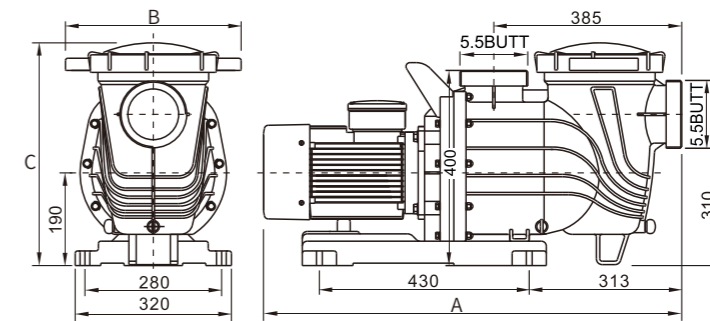

QH.Curve of The Pump

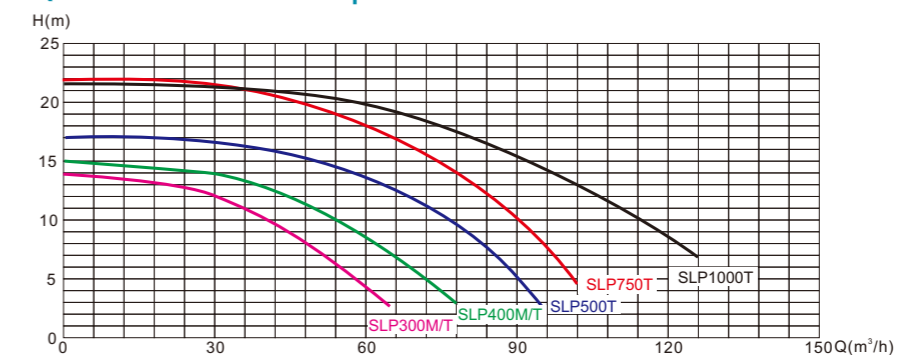

Model	Q-Max (m³/h)	H-Max (m)	Current (A)		Input power		A Length (mm)	B Width (mm)	C Height (mm)	Connection size (inch/mm)		Weight (kg)	Packing size (mm)
			220V/50Hz	380V/50Hz	kW	HP				3"	4"		
WL-SLP300M/T	64.8	14	10	4.1	2.2	3	800	360	456	88.9	110	45.5	840×395×600
WL-SLP400M/T	78	15	14	5.2	3.0	4	800	360	456			47	
WL-SLP500T	94.8	17	---	8.2	4.0	5	857	360	456	90	114.3	54.5	930×395×600
WL-SLP750T	102	22	---	9.6	5.5	7.5	857	360	456			60.3	
WL-SLP1000T	126	21.5	---	11.1	7.5	10	887	360	456	64.5			

LCAP SERIES PUMP

Engineered for aquaculture and commercial pools, LCAP series corrosion-resistant stainless steel pump delivers powerful, low-noise operation. The single-phase motor features a built-in USA/Germany (I) thermal protector to prevent overheating and motor failure. Designed for heavy-duty use, it ensures reliable, energy-efficient water circulation in harsh conditions.



Features:

- Protection standard: IP55
- Insulation class: F
- Liquid temperature: $\leq 104^{\circ}\text{C}$ (219.2 $^{\circ}\text{F}$)
- Ambient temperature: $\leq 50^{\circ}\text{C}$ (122 $^{\circ}\text{F}$)
- Max. Working pressure: 10.0bar

Materials:

- Pump housing: SS304
- Filter basket: SS304
- Shaft: SS304
- Impeller: SS304

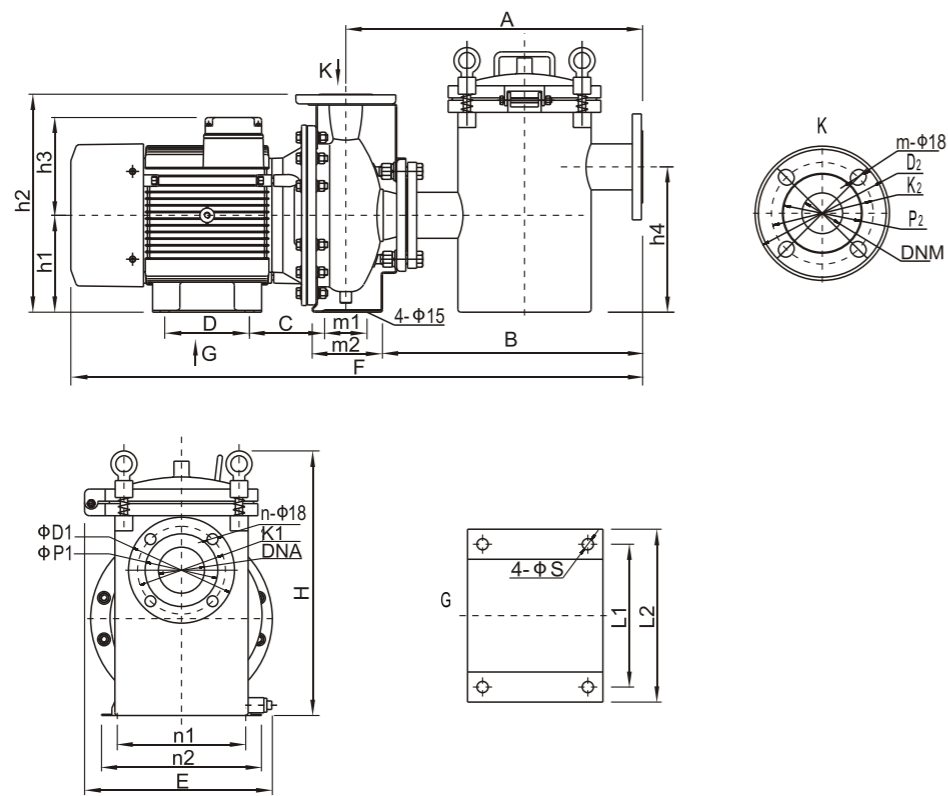

QH.Curve of The Pump

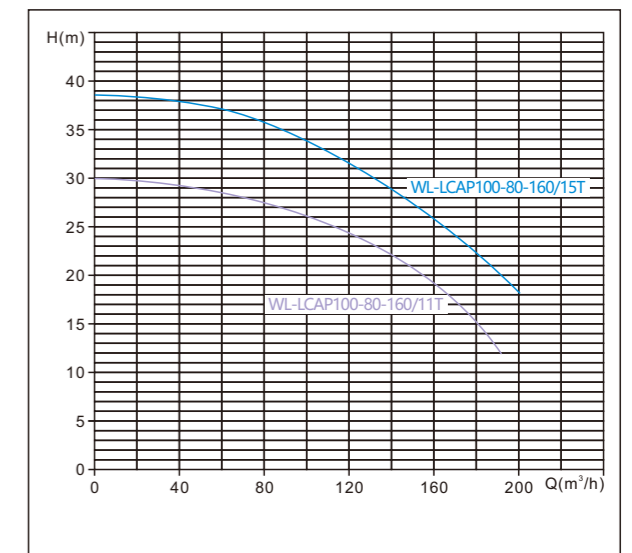
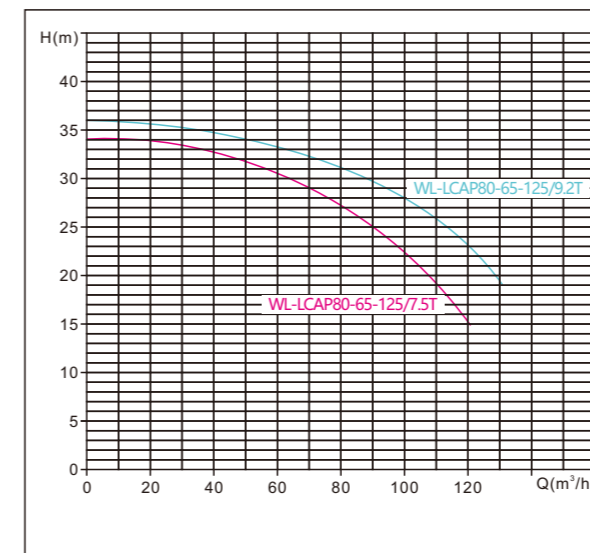
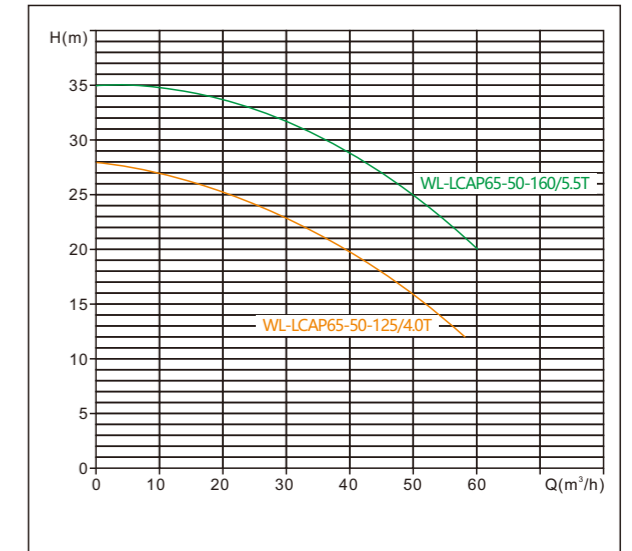
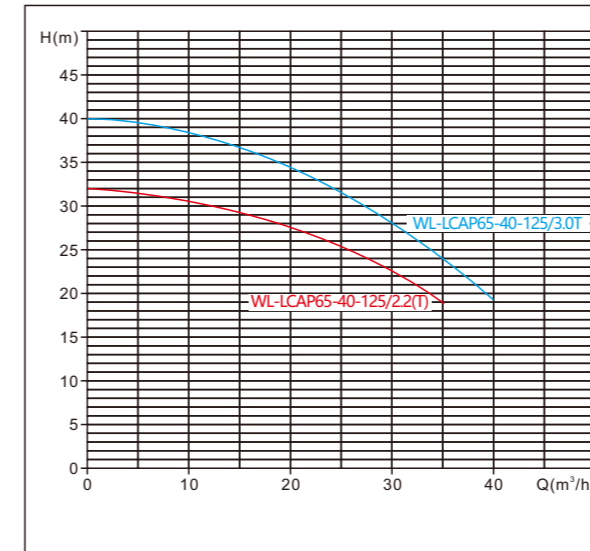

Model	Output power P ₂		Current (A)		Q-Max (m³/h)	H-Max (m)	Packing size (mm)
	kW	HP	220V	380V(T)			
WL-LCAP65-40-125/2.2(T)	2.2	3.0	14	4.9	35	28	890×350×570
WL-LCAP65-40-125/3.0T	3.0	4.0	---	6.3	40	32	890×350×570
WL-LCAP65-50-125/4.0T	4.0	5.5	---	9.6	55	28	930×350×570
WL-LCAP65-50-160/5.5T	5.5	7.5	---	11.1	60	35	1035×360×580
WL-LCAP80-65-125/7.5T	7.5	10	---	14.9	120	34	1035×360×580
WL-LCAP80-65-125/9.2T	9.2	12.5	---	18.3	130	36	1105×360×580
WL-LCAP100-80-160/11T	11	15	---	21.2	192	30	1225×410×630
WL-LCAP100-80-160/15T	15	20	---	28.6	200	38	1225×410×630

Model	E	F	H	h1	h2	h3	h4	A	m1	m2	n1	n2	B	C	D	φS	L1	L2	φD1	φK1	φP1	φD2	φK2	φP2	m	n	DNA	DNM
WL-LCAP65-40-125/2.2(T)	310	815	437	112	255	119	240	470	70	115	160	190	435	110	100	12	160	190	175	145	120	150	110	80	4	4	65	40
WL-LCAP65-40-125/3.0T	310	850	437	132	292	119	240	470	70	118	190	240	435	115	100	12	160	190	175	145	120	150	110	80	4	4	65	40
WL-LCAP65-50-125/4.0T	310	888	437	132	292	142	240	470	70	115	190	240	435	115	140	15	190	225	175	145	120	165	125	96	4	4	65	50
WL-LCAP65-50-160/5.5T	310	944	437	160	360	162	240	490	70	118	212	264	455	124	140	15	190	230	175	145	120	165	125	96	4	4	65	50
WL-LCAP80-65-125/7.5T	310	988	437	160	340	162	240	520	90	152	212	250	473	113	140	15	190	230	192	160	130	165	145	115	4	8	80	65
WL-LCAP80-65-125/9.2T	310	1056	437	160	340	179	240	520	90	152	212	250	473	175	140	15	216	255	192	160	130	180	145	115	4	8	80	65
WL-LCAP100-80-160/11T	363	1142	487	180	405	179	280	598	90	176	250	290	551	183	140	15	216	255	210	180	154	200	160	132	8	8	100	80
WL-LCAP100-80-160/15T	363	1184	487	180	405	179	280	598	90	176	250	290	551	183	140	15	216	255	210	180	154	200	160	132	8	8	100	80

ATB SERIES PUMP

Brass pumps are designed for maximum performance and economy in swimming filtration system. Besides they are extremely quiet in operation.

Features:

- Durable brass construction.
- High performance motors for maximum flow.
- Self-priming to insure proper filtration.
- Stainless steel mechanical seal.
- Closed impeller for longer motor bearing life.
- Heat-resistant seal.

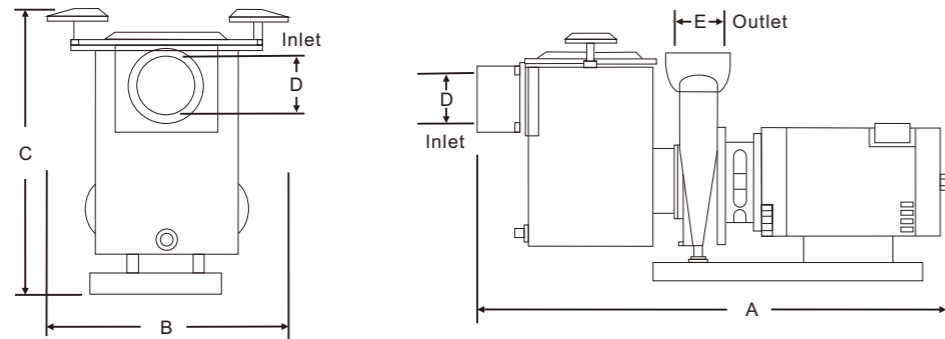

QH.Curve of The Pump

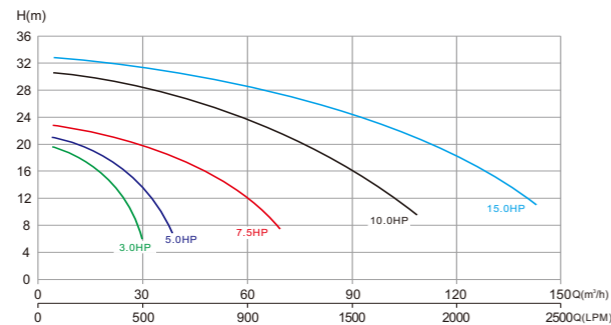

Model	Horsepower (HP)	Rated Power (kW)	Phase	Voltage (V)	Inlet/Outlet	A Length (mm)	B Width (mm)	C Height (mm)
WL-ATB030	3.0	2.25	3	380	2"/2"	660	200	200
WL-ATB050	5.0	3.8	3	380	3"/2.5"	720	230	400
WL-ATB075	7.5	5.5	3	380	3"/2.5"	720	266	400
WL-ATB100	10.0	7.5	3	380	4"/3"	1060	340	570
WL-ATB150	15.0	11.0	3	380	4"/4"	1090	340	570

AIR BLOWER

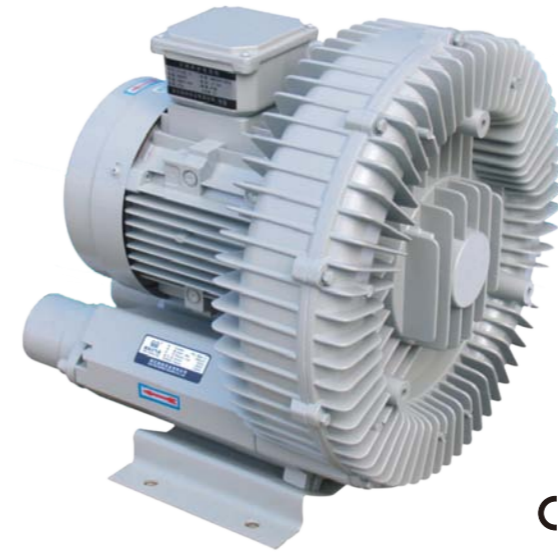

Features:

- Centrifugal vanes produce high pressure, great outflow, and low noise.
- A high-quality engine ensures a safe and steady effect.
- Oil free and pure compressed air.
- The machine has a wide range of power and can run a long service life.
- 50Hz or 60Hz are available on request.

Application:

- Swimming Pool/ Spa Pool
- Cooling for Molding
- Ultrasonic Washing and Cleaning Equipment
- Central Vacuum Cleaning System
- Printing Machine
- Sewage Treatment
- Water Treatment
- Agriculture Field
- Fish Farm
- Aquaculture

QH.Curve of The Pump

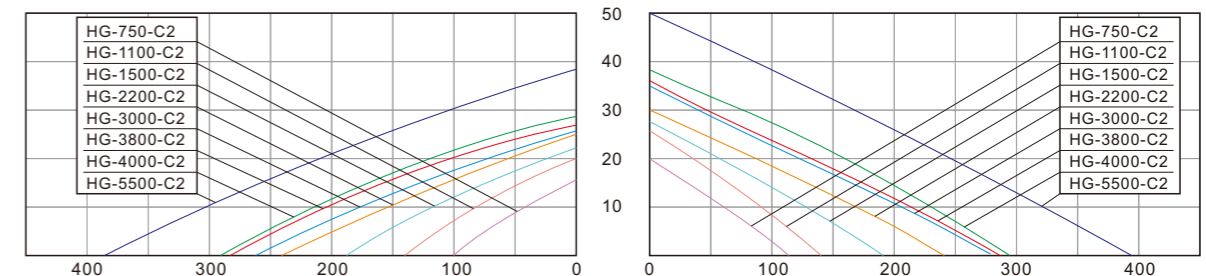

Model	Voltage (V)	Power (W)	Max.Pressure (Kpa)	Vacuum (Kpa)	Output (m³/h)	Pressure (KPa)	Weight (KGS)	Dimensions LxWxH(mm)
HG-750-C2	220	750	20	-16	110	<12	14	306×288×315
HG-1100-C2	220	1100	26	-20	135	<18	19	329×320×390
HG-1500-C2	380	1500	28	-22	180	<18	25	338×328×357
HG-2200-C2	380	2200	30	-24	240	<20	28	392×362×372
HG-3000-C2	380	3000	35	-25	260	<25	36	425×384×400
HG-3800-C2	380	3800	36	-26	280	<26	38	410×392×404
HG-4000-C2	380	4000	38	-28	280	<28	45	415×392×404
HG-5500-C2	380	5500	50	-35	380	<28	58	486×418×453