

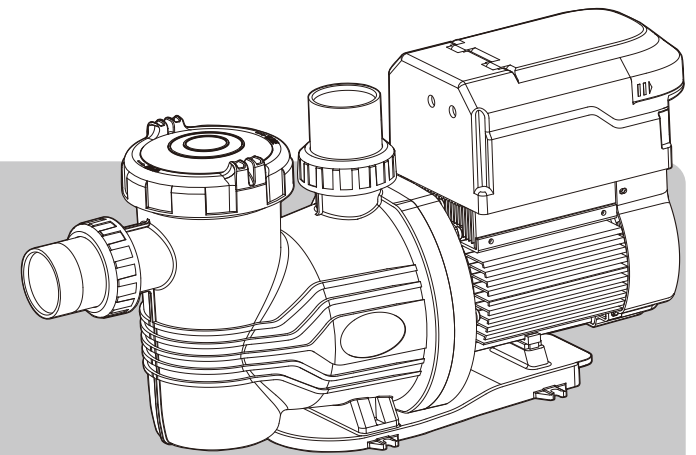

HV2 SERIES

INTELLIGENT VARIABLE-SPEED WATER PUMP INSTRUCTION MANUAL



- WL-HV2-100
- WL-HV2-150
- WL-HV2-200
- WL-HV2-100U
- WL-HV2-150U



GUANGDONG LASWIM WATER ENVIRONMENT EQUIPMENT CO., Ltd



To scan QR code for more information.
For more information please visit www.laswimwater.com

202507

The information in this paper instruction manual may not show the latest status of the product. In order to obtain the most accurate and latest product information, please contact our after-sales service department to obtain the electronic version of the manual. Thank you for your understanding and support.

1 OVERVIEW

The HV2 series intelligent variable-speed water pump is suitable for small residential swimming pools, small commercial swimming pools, water features, aquaculture, spa pools, water parks, etc

2 BASIC PARAMETERS

2.1 PUMP PERFORMANCE PARAMETERS

Model	Input Power supply(V/Hz)	Speed Range (r/min)	Output Power (HP)	Inlet and Outlet Connection (inch/mm)	Self-priming Height(m)	Ambient Temperature (°C)
WL-HV2-100	220-240V 50/60Hz	1000-2900	P2=1HP	2"/63	3	5-50
WL-HV2-150	220-240V 50/60Hz	1000-2900	P2=1.5HP	2"/63	3	5-50
WL-HV2-200	220-240V 50/60Hz	1000-2900	P2=2HP	2"/63	3	5-50
WL-HV2-100U	110-120V 50/60Hz	1000-2900	P2=1HP	2"/63	3	5-45
WL-HV2-150U	110-120V 50/60Hz	1000-2900	P2=1.5HP	2"/63	3	5-45

2.2 HEAD CURVES

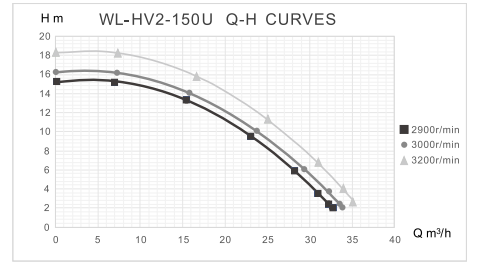
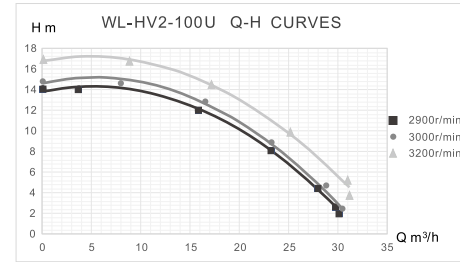
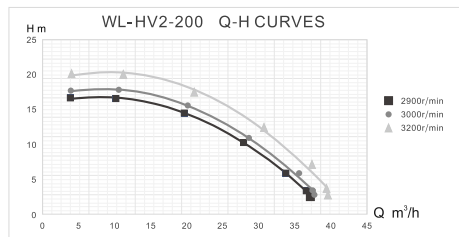
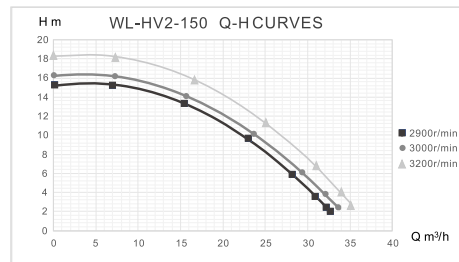
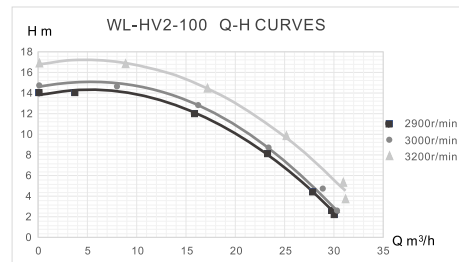

Model	Advised Pool volume (m³)	Max. Flow (m³/h)	Max. Head (m)	Head		
				8m	10m	12m
				Flow Rate(m³/h)		
WL-HV2-100	60-90	30	14	23	20	16
WL-HV2-150	80-120	33	15.6	26	23	19
WL-HV2-200	100-150	37	16.7	30	28	26
WL-HV2-100U	60-90	30	14	23	20	16
WL-HV2-150U	80-120	33	15.6	26	23	19

3 PRODUCT USER INSTRUCTIONS

3.1 SCREEN DISPLAY MODE



Speed Display



Flow Rate Display



Power Display



Error Code Display

3.2 INDICATOR LIGHT INSTRUCTIONS

Indicator Light Status	Status Description
(Wi-Fi Indicator) Red Flashing	Device Network Abnormality.
(Wi-Fi Indicator) White Solid	Device has completed network pairing, and network status is normal.
(Wi-Fi Indicator) White Flashing	Device is in network pairing mode, can use the app to complete pairing.
(Bluetooth Indicator) White Solid	Phone Bluetooth is connected to the device.
(Bluetooth Indicator) White Flashing	Device is in pairing mode, and the app can connect to the device.
(Switch Indicator) Red Solid	Device is powered on, but in off state.
(Switch Indicator) White Solid	Device is powered on and in operation state.
(Switch Indicator) Light Off	Device is powered off.

3.3 FUNCTION DESCRIPTION

Preset Operating Modes:

The factory preset 4 operating modes: Filter Mode, Backwash Mode, Boost Mode, and Turbo Mode.

Modes	Mode Definition Description
Filter Mode	Device is powered on and in operation, 1000-2900r/min.
Backwash Mode	The pump runs at 2900r/min for 1 minute, then returns to 2400r/min.
Boost Mode	The pump operated at 3000r/min for 5 minutes, then returning to the previous speed. After operating for 30 minutes, it enters the cooling mode.
Turbo Mode	The pump operated at 3200r/min for 5 minutes, then returning to the previous speed. After operating for 15 minutes, it enters the cooling mode.

Speed Adjustment Function:

Short Press or to adjust the speed by ± 50 r/min; Long press or to fast-forward/backward the speed by ± 50 r/min.

Speed/Power/Flow Display Switching:

Short Press or to cycle through the display, showing the current speed, current output power, and current flow rate.

Power On/Off:

Long press for 3 seconds to turn the pump on/off.

Device Wi-Fi Pairing/Unpairing:

Long press and at the same time for 3 seconds, and wait for a "beep" sound from the buzzer. The Wi-Fi indicator will then turn solid white, entering the pairing mode. Use the Tuya app on mobile phone to complete the network setup.

Device Bluetooth Connection/Disconnection:

Long press and at the same time for 3 seconds, and wait for a "beep" sound from the buzzer. The Bluetooth indicator will then turn solid white, entering the connection mode. Use your phone to complete the connection setup.

Speed Mode Switching:

Short press to cycle through Filter Mode, Backwash Mode, Boost Mode, and Turbo Mode. The corresponding mode will have a solid white light (Turbo Mode will have a red light, and both Turbo and Boost modes share the same icon).

Scheduling Function:

Short press to enter the scheduling mode, short press or to adjust the schedule time, short press to confirm the setting of the two schedule times, based on the display on the device screen, short press or to adjust the speeds for the two scheduled times, then short press again to confirm and save the schedule settings. Once the schedule setup is complete, the schedule selection button light will turn off.

Status Mode Switching:

By toggling the external physical button inside the pump wiring cover, you can switch between different device status modes, the corresponding status mode will be indicated by a solid white light on the indicator.

3.4 APP DOWNLOAD

Search for "tuya" on Google Play and App Store and download it, click on the upper right corner of the Tuya main interface to "Add Device", and follow the "Wi-Fi Network Setup for Device/Cancel Network Setup" instructions to connect the water pump.

3.5 PANEL USER INSTRUCTIONS

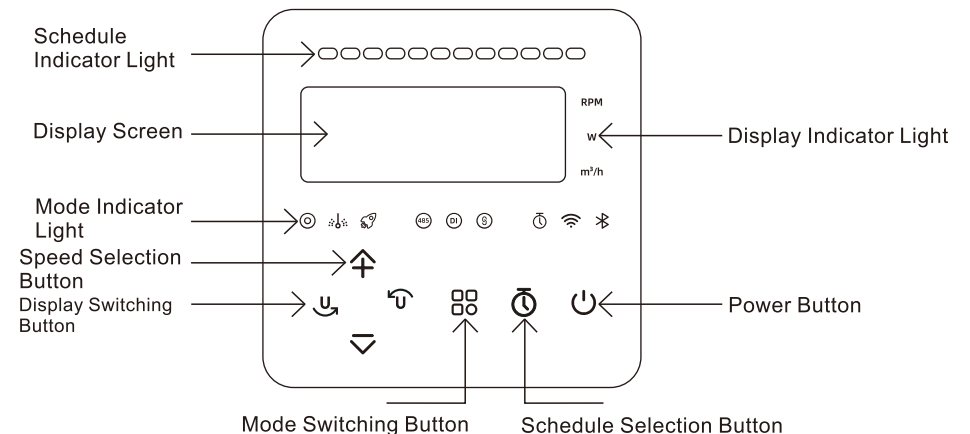

3.6 APP FUNCTION DESCRIPTION

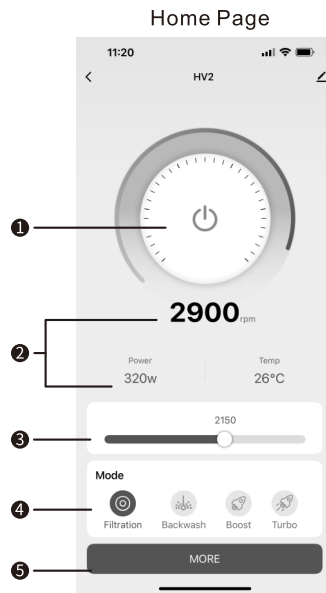

- ① Press the power button in the center of the dial to turn on/off pump.
- ② View real-time data for current speed, power, and ambient temperature (If a sensor is connected, it can display real-time data for power, ambient temperature, head, and current flow rate.)

Power	Temp	Head	Flow
1500w	26°C	14m	31m ³ /h

- ③ Press and hold the slider and slide it left or right to adjust the target speed.
- ④
 1. Filter Mode: The device is powered on and in operation, with a speed range of 1000-2900r/min;
 2. Backwash Mode: The pump runs at 2900r/min for 1 minute, then returns to 2400r/min;
 3. Boost Mode: The pump runs at 3000r/min for 5 minutes, then returns to the speed before starting the Boost Mode. After a total of 30 minutes of operation, it enters cooling mode.
 4. Turbo Mode: The pump runs at 3200r/min for 5 minutes, then returns to the speed before starting the Turbo Mode. After a total of 15 minutes of operation, it enters cooling mode.
- ⑤ Click "More Settings" to enter the menu page.

Power Off Page

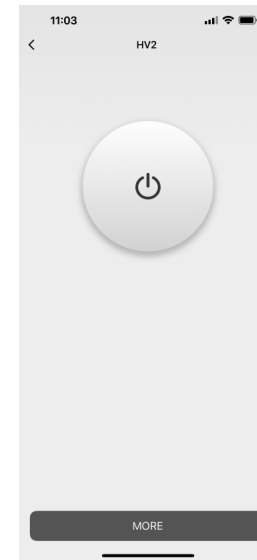

RS-485 Page

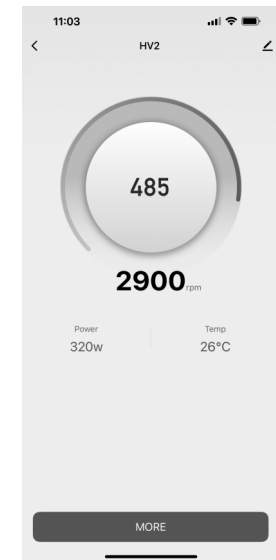

Dry Contact Page

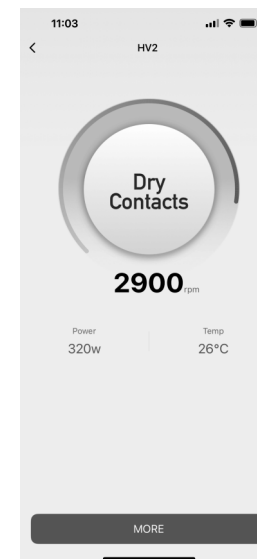

Mirroring Function Page

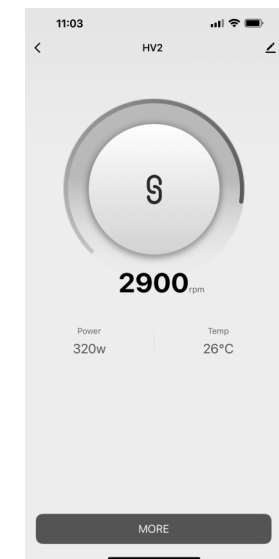

Menu Secondary Page

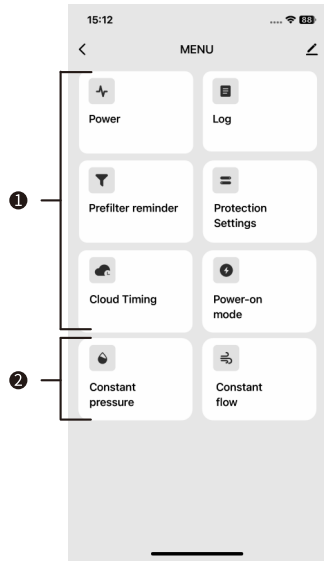

1. The menu bar page includes "Power Consumption, Pump Log, Filter Basket Reminder, Protection Settings, Cloud Timing, Power-On Mode, Constant Pressure , and Constant Flow ".
2. 1. "Constant Pressure and Constant Flow " will only be displayed on the page after sensors are connected.

Pump Log Page

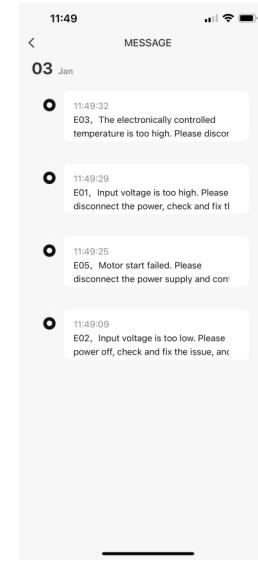

1. Detailed error messages can be viewed.

Power Consumption Page

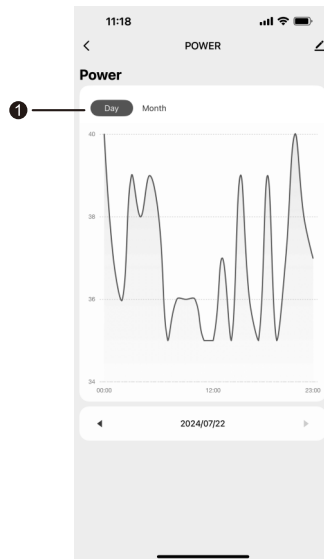

1. Click on "Day" or "Month" on the curve graph to select the timeline;
2. Click on the curve in the table to display the specific energy consumption values;

Filter Basket Reminder Page

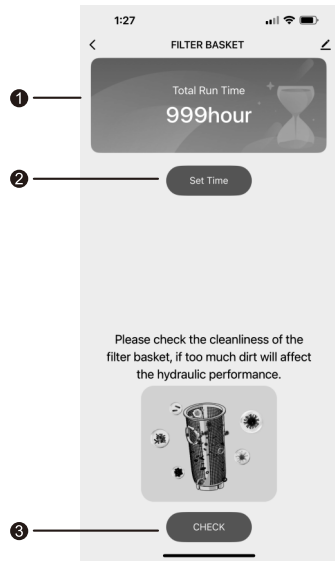

1. The card will display the cumulative runtime of the pump.
2. 1. When a reminder time is set, a pop-up will appear at the bottom after the device reaches the specified runtime, reminding the user to check the cleanliness of the filter basket. By clicking the "Set Reminder Time" button, you can set the reminder time for the next filter basket check.
2. The reminder time can be set within a range of 1000 to 10000, with a step increment of 500. Click "Confirm" to complete the setting for the next reminder time.

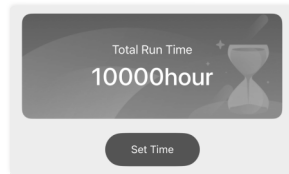

3. 1. The reminder to check the filter basket will only appear at the bottom of the page after the reminder time is set and the device reaches the specified runtime.
2. Clicking the "Check" button will open the "Disassembly Guide" pop-up. After disassembling and cleaning the filter basket, click the "Confirm" button to reset the cumulative time, and the reminder at the bottom of the secondary page will disappear. If you click the "Close" button in the top-right corner, it will indicate that the cleaning reminder is ignored, and the reminder at the bottom of the secondary page will remain.

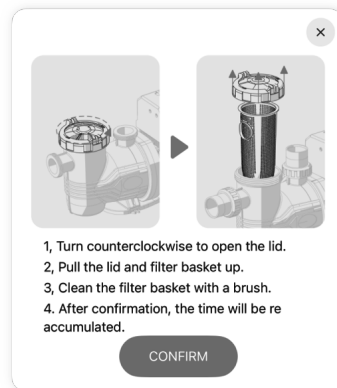

Protection Settings

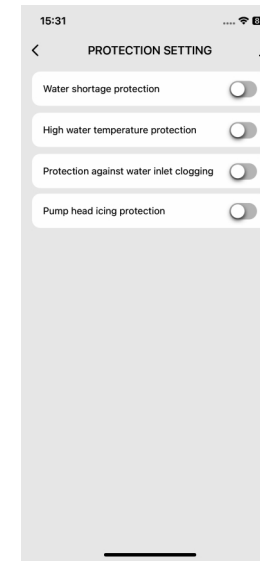

1. Swipe left or right to toggle the "Low Water Protection" on or off.
2. When the pump is connected to the sensor kit, the "High Temperature Protection, Anti-blockage, and Anti-freeze Protection" options will appear. Swipe left or right to toggle these protections on or off.

Cloud timing page

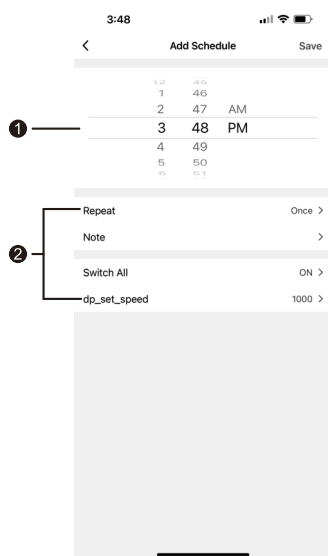

1 Click on "Add", scroll up and down to select the specific time;

2 1. Click on "Repeat" to enter the settings page, set the execution rules for this timer, and you can check or uncheck them;

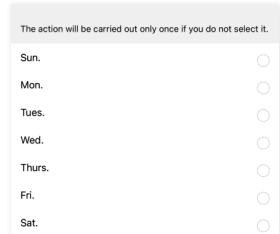

2. Click on the "Notes" to enter the settings page, make a note of this schedule, then click "Save" to generate the note, click "Cancel" to return to the previous page;

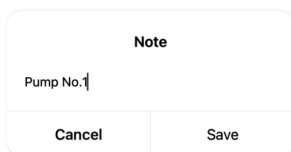

3. Click the main switch to enter the settings page, and adjust the timing for the automatic start and stop;

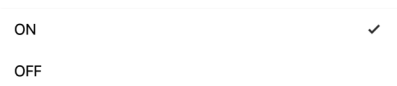

4. Click on the current speed to enter the settings page, set up the speed for this timing;

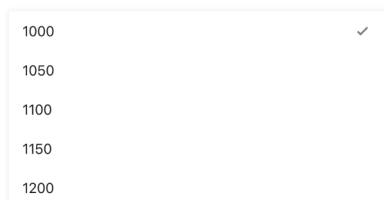

Scheduled Timers Page

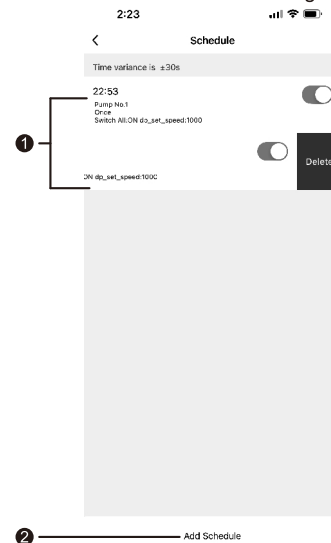

1 1. You can view the content of the scheduled settings;
2. Use the sliding function to turn on and off the schedule;
3. To delete the unnecessary scheduled plans, swipe left;

2 Click the "Add Schedule" button at the bottom of the screen to add more timing plans again;

Power-on Mode Page

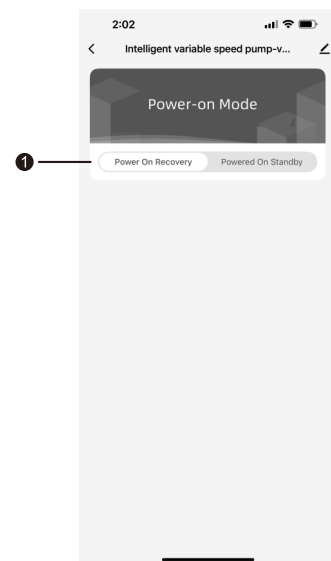

1 1. Enabling "Power-on Recovery" will set the device to its default power-on state after it is powered on. If the WiFi is disconnected and then reconnected, the system will automatically maintain the settings before the disconnection.
2. Enabling "Power-on Standby" will set the device to its default standby state after it is powered on. If the WiFi is disconnected and then reconnected, the system will automatically maintain the settings before the disconnection.
3. "Power-on Recovery" and "Power-on Standby" are mutually exclusive states.

Constant Pressure Function: According to the water outlet pressure of the water pump set in the program, the water pump automatically adjusts its speed to achieve constant pressure to transport water.

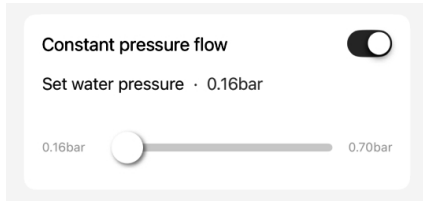

Constant Flow Function: According to the flow rate of the water pump set in the program, the water pump automatically adjusts its speed to achieve a constant flow rate to transport water. "Constant Water Flow" and "Intelligent Constant Water Flow" are mutually exclusive.

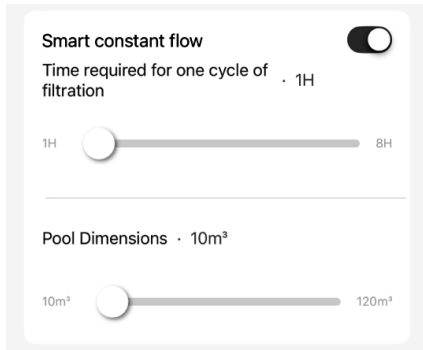
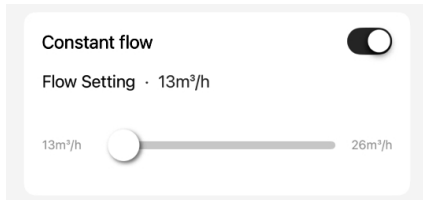

4 PRODUCT STRUCTURE AND DIMENSIONS

4.1 CONNECTION SIZE (INLET / OUTLET)

The pump comes with 2" connection. The user can use water pipe adapters to match different sizes of pipes.

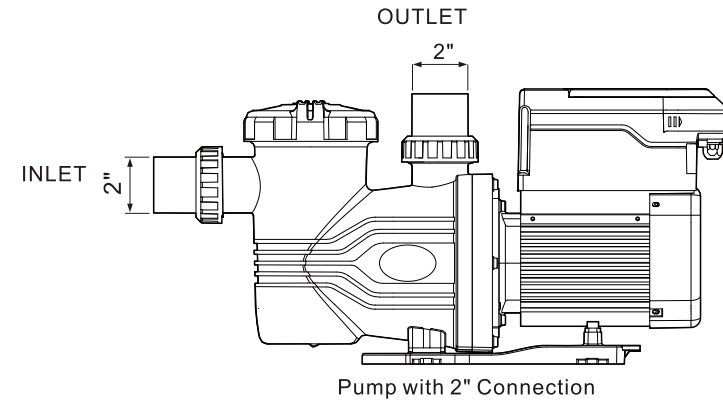

4.2 PRODUCT DIMENSIONS

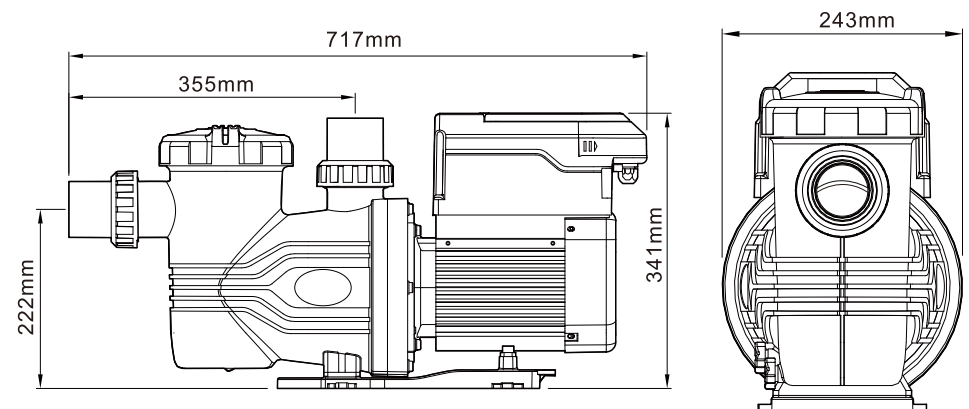

4.3 Pump Disassembly / Reassembly Diagram

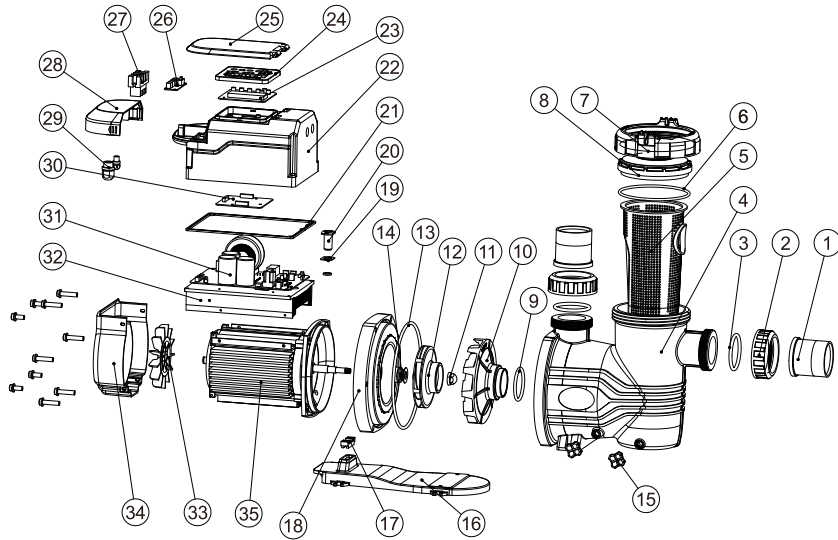

1	Pipe fitting	10	Diffuser	19	Terminal Gasket	28	Wiring Cover
2	Coupling nut	11	Impeller Nut And O-ring	20	Motor Terminal	29	Lock for cable 18&10
3	Pipe fitting O-ring	12	Impeller	21	Controller Box Gasket	30	Interactive Board
4	pump body	13	Seal Plate O-ring	22	Controller Box	31	Drive Board
5	basket	14	Mechanical Seal	23	Key Board	32	Drive Board Radiator
6	Transparent lid O-ring	15	Drain Plugs (×2)	24	Cover For Key Board	33	Fan
7	Nut for Lid	16	Base	25	Front Cover For Control Box	34	Fan Cover
8	Transparent lid	17	Motor Pad	26	Drive Connector	35	Motor
9	Diffuser O-ring	18	Seal Plate	27	Wiring Terminal Block		

5 INSTALLATION

5.1 Guidelines for Disassembling and Assembling Screen Orientation

Always disconnect power to the pump at the circuit breaker before performing the following steps.

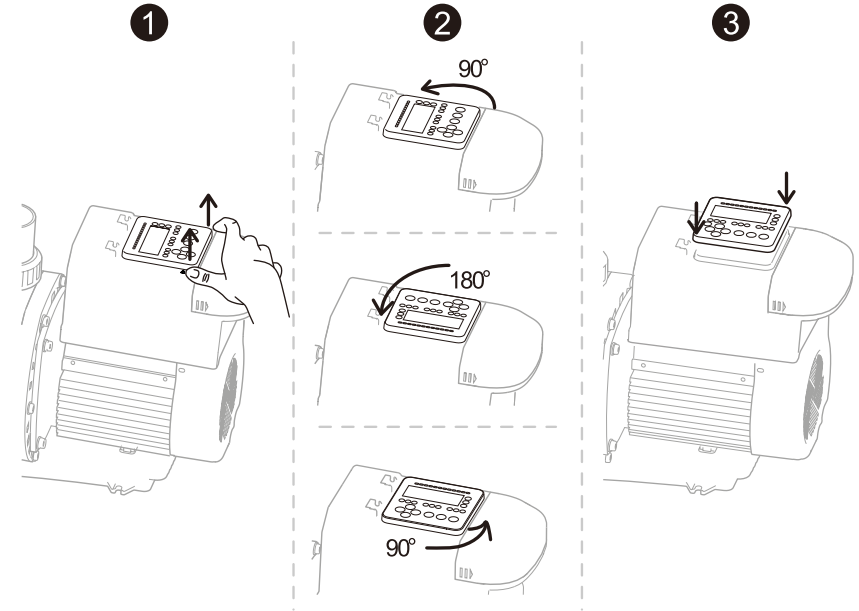

5.2 Wiring Guide

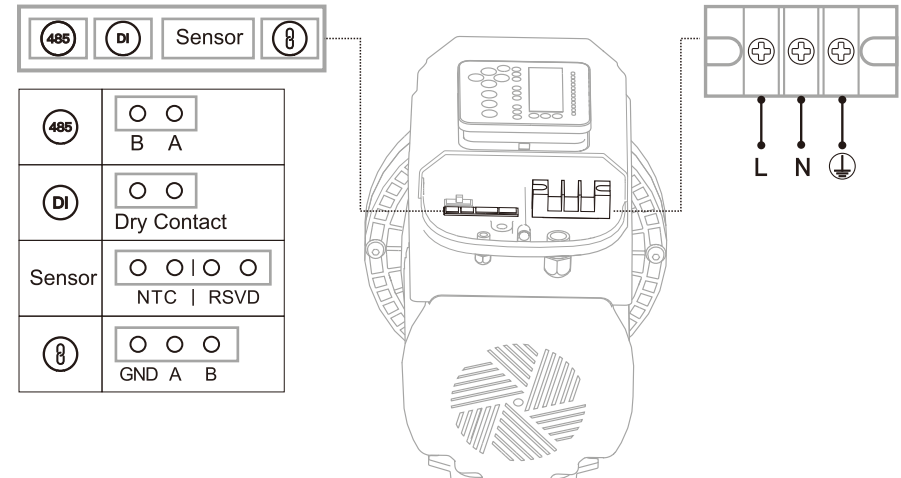

5.3 Mirroring Function

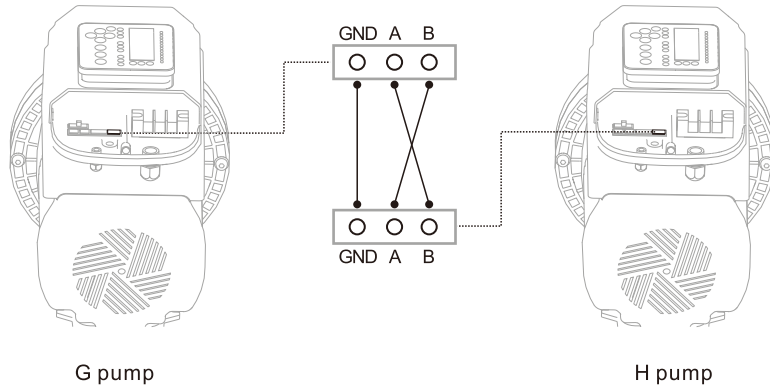

Wiring and Debugging: The mirroring function interface of the two pumps uses a three-core wire connection, with GND connected to GND, A to B, and B to A, to complete the wiring. Switch one of the pumps to mirroring mode using the dip switch (Note: If both are switched to mirroring mode, the mirroring function cannot be activated).

Function Description: Assuming Pump G is the primary device and Pump H is the standby one, when Pump G experiences shutdown, alarm, or power outage, Pump H will automatically start. If Pump G starts up normally, Pump H will automatically stop, meeting the operational criteria of one active and one standby.

CAUTION

- A: When/Before opening the nut cover, close the water inlet and outlet valves, loosen the drainage plug to release the air or water pressure inside the water pump. Do not loosen the drain plugs, strainer pot lid, or other parts while the water pump is working.
- B: Tightening the ring lock should only be done with matching specialized tools or wrenches.
- C: The water pump must not work without water, as this can damage the mechanical seal, leading to water leakage or overflow. Never close the outlet valve while the water pump is working, as this may cause damage to the pump.
- D: In areas with low temperatures, if the water pump is not going to be used for a long time, please open the drainage plug to empty the water from the pump to prevent freezing and damage.
- E: If the water pump is not used for a long time, please disconnect the power supply and close the water pump's inlet and outlet valves.
- F: Before the initial start-up of the water pump and when resuming use after a long period of inactivity, open the fan cover and check whether the fan can rotate. Please do not turn on the pump if the fan fails to rotate.
- G: If the water pump has been powered off for more than 7 days, it is recommended to connect to an APP or mini-program to synchronize the time after powering on.

6 FAULT PROTECTION AND FAULT PROMPTS

Fault Code	Fault Name	Fault Description
E001	Overvoltage Protection	Pump input voltage too high, check the power supply. Turn off the power for 3 seconds before turning it on,
E002	Low Voltage Protection	Pump input voltage too low, check the power supply. Turn off the power for 3 seconds before turning it on.
E003	Over-heated Protection	The internal temperature of the pump is too high, and the over-heated protection is activated, check whether the operating environment temperature is too high, or whether if the air outlet is blocked. Turn off the power for 3 seconds before turning it on
E004	Phase Failure	Motor not start, check motor internal wiring if wrong connection or loosen.
E005	Start up Failure	Motor failed to start, check circuit if normal. The pump motor failed to start normally after repeating 5 times, maybe the motor or the driving circuit is abnormal. (Instantaneous current sampling circuit failure.)
E006	Water Shortage Protection	The water pump is idling. Check whether water intake is blocked or the water inlet valve is not open. Turn off the power for 3 seconds before turning it on
E007	Place Holder	
E008	Overload Protection	The water pump runs abnormally and the overload protection starts, please disconnect the power supply and contact after-sales support for assistance.
E009	OTA Upgrade Failure	OTA upgrade failed. Please check the network and upgrade again.
E010	Place Holder	
E011	Keypad Failure	The pump key panel is malfunctioning, check whether the pump internal wiring is loose.
E012	PFC Module Abnormal	The pump is failure. Please contact the service for maintenance.
E013	Anti Freezing Protection	When the current water temperature is below 10°C, the pump will run for 1 minute every 5 minutes, to prevent the pump housing from damage by icing.
E014	High Ambient Temperature Alarm	The current ambient temperature is above 50°C.
E015	High Medium Temperature Alarm	The current medium temperature is above 55°C. It may be because the outlet valve is closed.
E016	Submergence Alarm (Reserved)	The pump is submerged in water (Reserved).
E017	Outlet Blockage Protection	The outlet pressure is too high. The pump increases the speed to 3200 RPM to try to flush out the obstruction, repeating this process twice every 5 minutes. If the obstruction is still not cleared, the pump will shut down to for self-protection.
E018	Inlet Blockage Protection	Abnormal negative pressure at the water inlet.

7 PRECAUTIONS

- (1) The wiring must be correctly configured according to the wiring diagram indicated in the specification, and wrong wiring may lead to safety accidents.
- (2) Please avoid using under the following environmental conditions:
 - ① Environment with severe vibration.
 - ② Near flammable objects.
 - ③ In an environment prone to condensation, in an environment with a relative humidity of 90% or more.
 - ④ Please do not store the product with external force or heavy load, and do not place heavy objects on the product, otherwise it may cause damage to the appearance of the product or damage to the device.
- (3) Please avoid storing in high temperature and humid places. It's recommended to store the product with a humidity of 40-60% RH and a temperature of 20-30°C for a long-term storage.
- (4) In case of an error, please refer to the error code prompt for troubleshooting. In case you still cannot solve it, please contact the salesman or call after-sales support.