

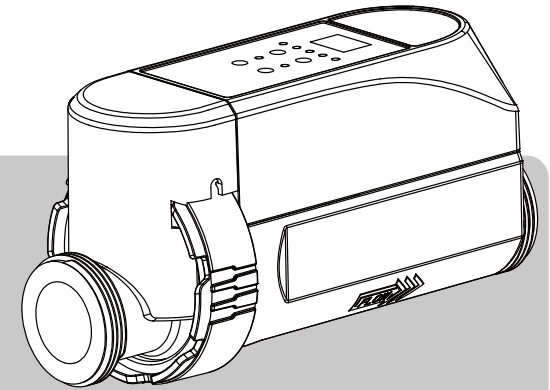

SALT CHLORINATOR EC PLUS SERIES

INSTALLATION AND USER MANUAL



- EC PLUS 8
- EC PLUS 12
- EC PLUS 16
- EC PLUS 20
- EC PLUS 30



GUANGDONG LASWIM WATER ENVIRONMENT EQUIPMENT CO., Ltd



To scan QR code for more information.
For more information please visit www.laswimwater.com

202408

Please Read The Manual Carefully Before Use.

WARNING

First of all, thank you for choosing salt chlorinator EC Plus series. For your best experience of the product, prevent the occurrence of accidents, please carefully read the whole content of this manual before the assembly and the use of the salt chlorinator. Please strictly follow the manual for your own safety and operation of the salt chlorinator. Neglecting the safety warning may cause serious consequences such as : grievous injury, property loss and may even cause life safety threatening consequences.

NOTICE

1. The installation and the maintenance must be done by a licensed electrician. Or else there would be risk of electrocution, grievous injury, property loss and may even cause life safety threatening consequences.
2. Before any maintenance or operation, ensure that the salt chlorinator is power-unplugged, all machinery are turned off and power source is turned off.
3. The external power adapter of the chlorinator must be installed to a power source that contains a leakage switch protection.
4. The chlorinator should be installed in a well ventilated area, to help the chlorinator to cool down. Do not install in an area where the electronic component of the chlorinator could be damaged by moisture and rain.
5. Installation personnel must carefully read this manual before installation. If any improper or mistaken operation occurs, please contact the nearest authorized dealer or contact technical support department.
6. When parts are damaged, please prioritize the purchase of the replacement part at the manufacturer or authorized dealer.

1 PRODUCT SUMMARY

Salt chlorinator uses the most advanced microcomputer technology. It is both multi-functional and easy to operate. It contains functions such as self-cleaning and malfunction alarm. You can set the chlorine production to match your need, to achieve the goal of efficiency and environmental friendliness.

Product distinguishing features:

- 1.1 Controller and the chlorinator are integrated for easier installation and more space-saving.
- 1.2 Water inlet and output are designed on the same axis to decrease the need for pipe arrangement.
- 1.3 Design for easy access to the titanium polar plate for simple installation and maintenance.
- 1.4 Users can choose from different levels of chlorine production. Can alter the level according to need, which is energy efficient and environmental-friendly.
- 1.5 The chlorinator contains salinity level prompt and malfunction alarm.
- 1.6 The chlorinator contains water temperature protection (10° to 45°) and water shortage protection. This can effectively extend the service life of the machine.
- 1.7 Water level detection. The chlorinator only operates when the sensor detects the presence of water.
- 1.8 When powered-on automatically initiates the last work setting from system memory.

WARNING

Automatic power on means when power shortage occurs during operation, and when power recovers the system automatically turns on.

Memorizing the setting from last operation means the condition before a power shortage, or the system setting before a system failure, including the "Boost" state, the "Boost" state timer is reset.

Model	Chlorine production	Recommended pool volume (m ³)
EC PLUS 8	8g/h	One unit satisfy the chlorine need for the pool ≤ 35m ³ .
EC PLUS 12	12g/h	One unit satisfy the chlorine need for the pool ≤ 50 m ³ .
EC PLUS 16	16g/h	One unit satisfy the chlorine need for the pool ≤ 68 m ³ .
EC PLUS 20	20g/h	One unit satisfy the chlorine need for the pool ≤ 85 m ³ .
EC PLUS 30	30g/h	One unit satisfy the chlorine need for the pool ≤ 127 m ³ .

2 PRODUCT SIZE

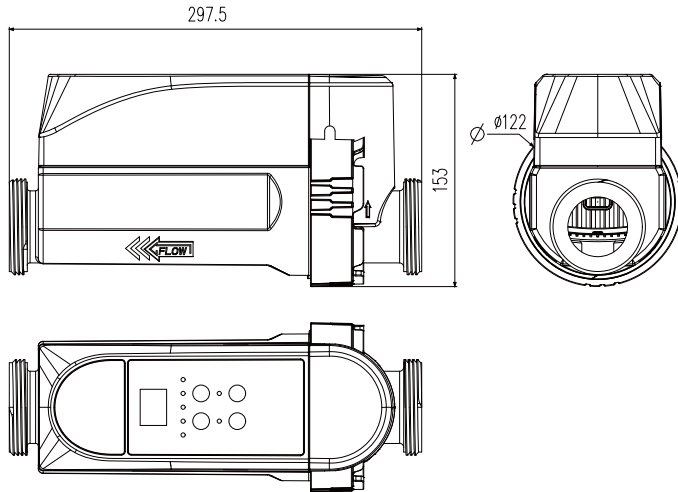

3 INSTALLATION INSTRUCTION

- 3.1 Before use, please ensure that the pipe used for installation is the same size with the salt chlorinator. The nominal diameter of the connection pipe of the chlorinator is : 1.5" (metric: $\varnothing 50\text{mm}$; imperial: 1.5" / $\varnothing 48\text{mm}$).
- 3.2 Before use, please ensure that the valve of the pipe connecting to the chlorinator is turned off.
- 3.3 Before installation, please clean any clutter or oil off of the pipes and the connection joint.
- 3.4 The salt chlorinator should be installed with the return pipe to the pool and by the bypass of the water treatment shown on the diagram. A adjust valve needs to be installed on the main pipe (as shown on Diagram 1 or Diagram 2).
- 3.5 Before installing the salt chlorinator, please ensure that the water flow matches the direction on the chlorinator indicates.
- 3.6 When connecting the pipes to the chlorinator, please use glue specialized for PVC.
- 3.7 The operating power of the chlorinator uses the external power adapter, input (AC110~220V/50~60Hz), output DC24V/5A.
- 3.8 The external power adapter of the chlorinator must be installed to a power source that contains a leakage switch protection.

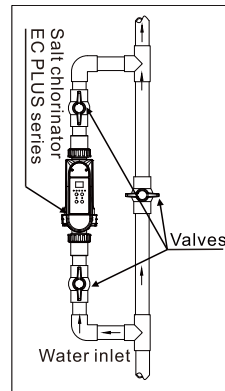
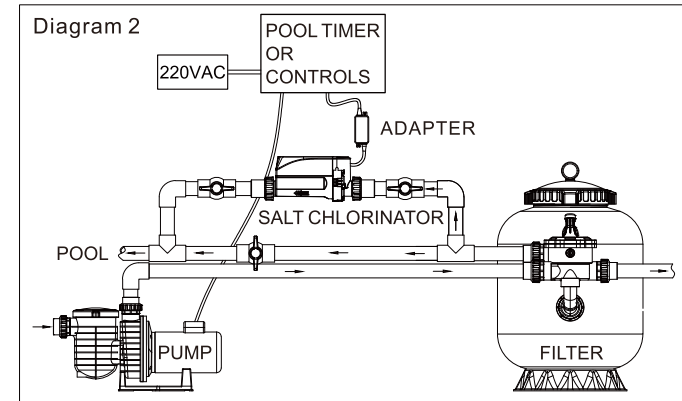

Diagram 1

- 3.9 The chlorinator should be installed in a well ventilated area, to help the chlorinator to cool down. Do not install in an area where the electronic component of the chlorinator could be damaged by moisture and rain.
- 3.10 In the process of use, the chlorinator should avoid direct sunlight that may accelerate the aging of the shell of the chlorinator.



4 OPERATING INSTRUCTION

- 4.1 When the salt chlorinator is connected, turn on the valve connecting the chlorinator, adjust the water flow with the valve to ensure enough water flow goes through the salt chlorinator.
- 4.2 To connect the power cable, open the decorative cover of the chlorinator in the direction indicated by the arrow of the cover. Plug the round plug into the power connector (as indicated in diagram 3), then mount the decorative cover back to the original position.

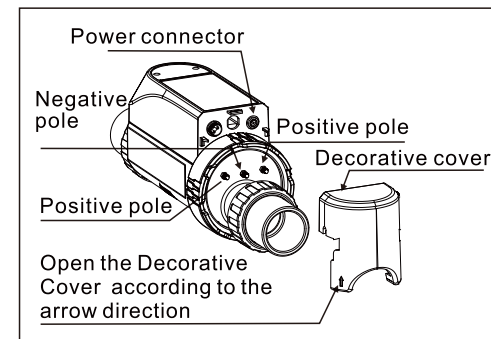

Diagram 3

- 4.3 Before operation, make sure that the salt concentration of pool water is in the normal operating range, otherwise it can reduce the service life of titanium polar.
- 4.4 Close the electricity leakage switch to activate the display. Press the STANDBY/ON operate button, the operation light would turn from red to green, and the chlorinator would start operating.

NOTE

The chlorinator can only function when the water level detector detects the presence of enough water flow.

4.5 By pressing the “+” or “-” button, users can adjust the chlorine production level to need; users can choose from 1~5 level, level 1 is the smallest and level 5 is the highest. The higher the level, the higher the production of chlorine is produced.

4.6 If the rate of chlorine production needs to be accelerated, press the “BOOST” button. The chlorinator would operate at maximum capacity for 8 hours, then return to the original preset state.

4.7 Parameters check: press the “” acceleration key multiple times while the chlorinator is off to look up different parameters below:

- 4.7.1 Temperature of MOS tube
- 4.7.2 Water temperature
- 4.7.3 Input voltage
- 4.7.4 Version number
- 4.7.5 Time period of continuous operation; The system automatically exits the inquiry after 3 seconds.

4.8 Time setting for continuous operation: press the “” acceleration key 5 times while the machine is off to display the time period of continuous operation. Change the time periods of continuous operation by pressing “+” or “-”. The length of time range from 1- 24 hours. For example, if the value is set at 12, the chlorinator would operate for 12 hours (then turn off) after it has been turned on. The chlorinator will stop for 12 hours and turn on for 12 hours again following this cycle.

NOTE

The chlorinator is preset to continuous operation for 12 hours; if 24 hour non-stop operation is needed, the time setting for continuous operation would have to be set at 24; the system automatically exits the setting after 3 seconds.

4.9 When the chlorinator reports a malfunction or warning, press “” acceleration key to clear it and resume to normal operation. to be pressed to clear the malfunction before the chlorinator can operate again.

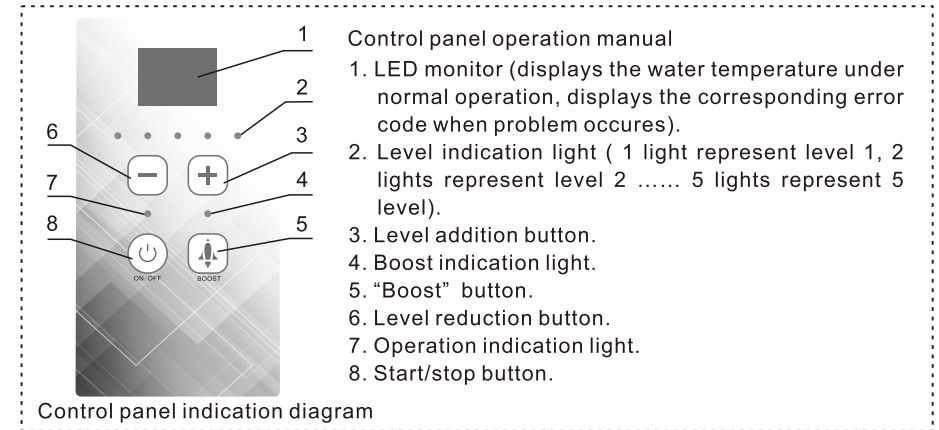

5 ERROR CODE AND CORRESPONDING SOLUTIONS

Error code	Reason of error	Remark	Solution
E1	The temperature of the MOS tube is too high	◆ After the malfunction is solved, the fault will be eliminated automatically, and the chlorine production will resume automatically.	◆ First check whether there is an E6 fault code. If there is no E6 fault code, press the “BOOST” to eliminate the error code and then downshift.
E2	The water temperature is beyond the normal range	◆ The normal range of operating temperature is 10~45 degrees Celsius	◆ First check if E7 error code is presence, if it is, check if the temperature sensor is attached. If it is, please change the sensor; ◆ If E7 error code is not presence. Please check that the water is within the range of operational temperature.
EH	Water temperatures above 45°C will cause the chlorinator stop working.	◆ Normal operating water temperature range: 10-45°C	◆ Check whether the water temperature above 45°C, otherwise the temperature sensor may be damaged. If the water temperature is too high, add tap water to cool it down.
EL	Water temperature is below 10°C, but the chlorinator is still working.	◆ Normal operating water temperature range: 10-45°C	◆ Use a thermometer to check whether the water temperature is lower than 10°C. If not, the temperature sensor may be damaged, replace the temperature sensor in time
E3	No water	◆ Normal operation requires enough water in the chlorinator	◆ First, check if the water level detector is attached. If it is, check if water is lacking or air was present. If water is presence, wash the water level detector.
E5	The salt concentration is too low	◆ Normal salt concentration range is 2700-4500ppm	◆ First use a salinity meter to check the salt concentration in the pool. If the salt concentration level in the pool is below 2700ppm, add salt to the pool. When the salinity level of the pool reaches the normal operation salinity level, the error code should disappear. And the machine should function again.
E6	MOS tube NTC thermistor malfunctioned	◆ The error code will automatically eliminated after the malfunction is solved.	◆ Contact the supplier to repair or replace the controller circuit board.

E7	Water temperature sensor malfunctioned	◆ The malfunction must be removed manually	◆ First check if the corresponding temperature sensor is attached, if it is please replace the sensor.
E8	The input voltage is too high or too low	◆ The malfunction must be removed manually	◆ Please change the hardware of the power supply.
EA	Electrode malfunction	◆ The malfunction must be removed manually	◆ First check if the electrode is attached. If it is, please change the electrode.

EXTRA : THE OPERATING CONDITION AND MAINTENANCE OF THE SALT CHLORINATOR

1. The mixture and maintenance of water and salt.

1.1 The calculation of the amount of water:

Knowing the capacity of the pool is the first step in adding salt to the pool.

Rectangular pool: length (meter) x width(meter) x average depth (meter) = pool water capacity (cubic meter).

Circular pool: diameter(meter) x diameter(meter) x average depth(meter) x 0.785 = pool water capacity (cubic meter).

Ellipse pool: length (meter) x width(meter) x average depth(meter) x 0.893 = pool water capacity (cubic meter).

Beveled pool : pool volume (cubic meter) x 0.85 = pool water capacity (cubic meter).

1.2 The type of salt

The purer the salt, the more the advantageous of the salt chlorinator would operate. This will also extend the service life of the chlorinator. The Sodium Chloride (NaCl) in the salt should be at least 99.6%. Best if the salt is dehydrated granular food grade sea salt.

WARNING

- A. Please do not use rock salt, its impurity may shorten the service life of the chlorinator.
- B. Do not use Calcium Chloride as salt, only sodium chloride can be used.
- C. Avoid using anti-blocking agent (sodium cyanide, aka YPS, is poisonous and corrosive) salt, this kind of salt may change the color of the pool surface and the equipments inside.
- D. Can use water treatment salt pills, but it make take very long time to melt in the water.

1.3 Adding the right amount of salt

Most pools contains certain amount of salt, the concentration of the salt in water will vary depending on the water source and the sterilizing agent used. Users can use hand-held NaCl tester or salinity pen to test the current salt concentration of the pool.

TIPS

- ◆ The best operating salt concentration level of the salt chlorinator EC Plus series is 3500ppm (3.5kg of salt per cubic meter).
- ◆ When operating the salt chlorinator EC Plus series for the first time. Add salt to the pool following the steps below:
 - A. Use a salinity meter to check the original salt concentration in the pool.
 - B. Add appropriate amount of salt , ensure that for each cubic meter water add 3.5kg of salt.
- ◆ The concentration of salt (ppm value) can be seen as the gram of salt within 1 ton of water. If the current salt concentration of a 100m³ pool is 850ppm (can be taken as 850g in 1 ton of water), how much salt is needed for the chlorinator to normally operate ?
- ◆ Salt need to be added (unit: gram) = water in the pool x (normal operation salt concentration – the current pool salt concentration) = 100 x (3500-850) = 265000 gram.

1.4 The correct way of adding salt

- a. Turn on the circulation pump of the pool, and let the water circulation begin.
- b. Turn off the salt chlorinator.
- c. Test the current salt concentration of the pool.
- d. Calculate the amount of salt needed to add to the pool according to the corresponding chart.
- e. Add salt to the pool around the side of the pool, so that it can quickly and evenly dilute into the water. Do not let salt accumulate on the bottom of the pool. Stir the water on the bottom of the pool if needed so the salt can completely dissolve.
- f. Run the circulation pump for 24 hours, so the salt can evenly distribute in the pool.
- g. 24 hours later, test the salt concentration of the pool again to see if it has reached optimum level.
- h. When the salt concentration of the pool has reached the desired level, turn on the salt chlorinator and other equipments. Once the chlorinator initiates, please set your desired level of chlorine production.

1.5 Decrease the concentration of salt The only way to decrease the concentration of salt is to drain a part of the pool's water and replacing it with fresh water.

1.6 In order to reduce the loss of chlorine by the UV radiating on outdoor pool water , dose Cyanuric acid of 20—100mg/L as chlorine stabilizer.

2. The maintenance of salt chlorinator

2.1 The maintenance of the electrolysis cell

To ensure the smooth operation of the salt chlorinator, the electrolysis cell should be checked every three months or after cleaning the filter, whichever comes first. Follow the steps below to complete the check:

- A. Before removing the electrolysis cell, close the inlet and output valve after shut down the salt chlorinator for 5 – 10 minutes.
- B. After removal of the electrolysis cell, check to see if there are flake-like sediments, debris, light colored layering in the inner surface. Wash with clean water.
- C. If there are white calcified substance on the titanium plate. Submerge the titanium plate into 4:1 water and hydrochloric acid solution to remove the calcified substance. Please wear rubber gloves and eye protection for safety.
- D. If there are major sediments that cannot be removed on one's own, please contact the seller for professional suggestion.