

INSTALLATION & OPERATION MANUAL OF PUMP

WL-HLLF075M

WL-HLLF100T

WL-HLLF100M

WL-HLLF150T

WL-HLLF150M

WL-HLLF200T

WL-HLLF200M

WL-HLLF300T

WL-HLLF300M

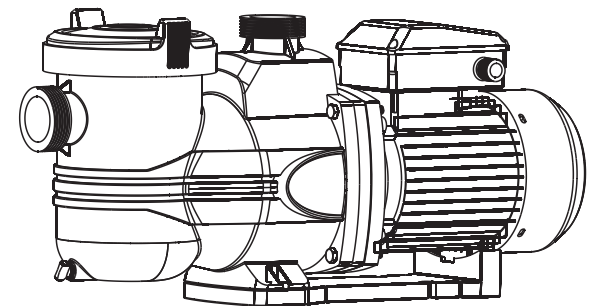

PUMP

1 IMPORTANT SAFETY INSTRUCTIONS

When installing and using this electrical equipment, basic safety precautions should always be followed, including the following.

READ AND FOLLOW ALL INSTRUCTIONS



WARNING

To reduce the risk of injury. Do not permit children to use this product. Risk of electrical shock. Connected only to grounding type receptacle protected by a ground fault circuit interrupter (GFCI). Contact a qualified electrician if you cannot verify that the receptacle is protected by GFCI.



CAUTION

Do not bury cord. Locate cord to minimize abuse from lawnmowers, hedge trimmers, and other equipment. In case the running parts will injure people, don't make the electric pump running before the pipeline have been connected.



WARNING

To reduce the risk of electrical shock, do not use extension cord to connect unit electric supply; provide a properly located outlet.

2 INSTALLATION

Only qualified, licensed personnel should install pump and wiring.

Pump mount must:

- ◆ Be located away from corrosive or flammable chemicals.
- ◆ Be solid - Level - Rigid - Vibration free. (To reduce vibration and pipe stress, bolt pump to mount.)
- ◆ Allow pump suction inlet height to be as close to water level as possible.
- ◆ Allow use of short, direct suction pipe (To reduce friction losses).
- ◆ Allow for valves in suction and discharge piping.
- ◆ Have adequate floor drainage to prevent flooding.
- ◆ Be protected from excess moisture.
- ◆ Allow adequate access for servicing pump and piping.



NOTICE

Use thread seal tape for making all threaded connections to the pump. Do not use pipe dope; pipe dope will cause stress cracking in the pump. Pump suction and discharge connections have molded in thread stops. DO NOT try to screw pipe in beyond these stops.

3 OPERATION



CAUTION

NEVER run pump dry. Running pump dry may damage seals, causing leakage and flooding. Fill pump with water before starting motor.

Before removing trap cover:



WARNING

Hazardous voltage.
Can shock, burn, or cause death.
Disconnect power before working on pump or motor.

1. STOP PUMP before proceeding.
2. CLOSE VALVES in suction and discharge pipes.
3. RELEASE ALL PRESSURE from pump and piping system.
4. NEVER tighten or loosen clamp while pump is operating!

If pump is being pressure tested, be sure pressure has been released before removing trap cover.

Do not block pump suction. To do so with body may cause severe or fatal injury. Small children using pool must ALWAYS have close adult supervision.

Priming Pump

Release all pressure from filter, pump, and piping system; see the filter owner's manual.

In a flooded suction system (water source higher than pump), pump will prime itself when suction and discharge valves are opened.

If pump is not in a flooded suction system, remove trap cover handle ring and trap cover; fill trap and pump with water.

Do not lubricate the trap cover O-Ring. The original equipment O-Ring contains a permanent internal lubricant.



NOTICE

If you replace the O-Ring with a non-internally lubricated O-Ring, you may need to apply a silicone based lubricant. Clean and inspect O-Ring; reinstall on trap. Replace trap cover and handle ring on trap; turn handle ring clockwise to tighten cover.

PUMP



NOTICE

Tighten trap cover handle ring by hand only (no wrenches)!
Pump should prime now. Priming time will depend on vertical length of suction lift and horizontal length of suction piping.
If pump does not prime, make sure that all valves are open, suction pipe end is under water, and that there are no leaks in suction pipe.

4 ROUTINE MAINTENANCE

The only routine maintenance needed is inspection/cleaning of trap basket. Debris or trash that collects in basket will choke off water flow through the pump. Follow instructions below to clean trap:

1. Stop pump, close valves in suction and discharge, and release all pressure from system before proceeding.
2. Remove trap cover handle ring (turn counterclockwise). If necessary, tap handles gently with a rubber mallet.
3. Remove strainer basket and clean. Be sure all holes in basket are clear, flush basket with water and replace in trap with large opening at pipe connection port (between ribs provided). If basket is replaced backwards cover will not fit on trap body.
4. Clean and inspect lid O-Ring; reinstall on trap.
5. Clean O-Ring groove on trap body and replace cover and handle ring. To help keep cover from sticking, tighten hand tight only.
6. Prime pump (see priming instructions).

5 TROUBLE SHOOTING

◆ MOTOR DOES NOT START

1. Disconnect switch or circuit breaker in off position.
2. Fuses blown or thermal overload open
3. Locked motor shaft
4. Motor windings burned out
5. Defective starting switch inside single phase motor
6. Disconnected or defective wiring
7. Low voltage

◆ LOW PUMP CAPACITY

1. Valve in suction or discharge line partly closed
2. Suction or discharge line partly plugged.
3. Suction or discharge line too small
4. Plugged basket in skimmer or hair and lint strainer

5. Dirty filter
6. Impellor clogged

◆ PUMP DOES NOT REACH FULL SPEED

1. Low voltage
2. Pump connected for wrong voltage

◆ MOTOR OVERHEATS (Protector trips)

1. Low voltage
2. Motor windings connected for wrong voltage on dual voltage model
3. Inadequate ventilation

◆ PUMP DELIVERS NO WATER

1. Pump is not primed
2. Closed valve in suction or discharge line
3. Leakage or air into suction system
4. Impellor clogged

◆ LEAKAGE OF WATER AT SHAFT

1. Shaft seal requires replacement

◆ HIGH PUMP PRESSURE

1. Discharge valve or inlet fittings closed too much
2. Return lines too small
3. Dirty filters

◆ NOISY PUMP AND MOTOR

1. Plugged basket in skimmer or hair in lint strainer
2. Worn motor bearings
3. Valve in suction line partly closed
4. Suction line partly plugged
5. Vacuum hose plugged or too small
6. Pump not supported properly

◆ AIR BUBBLES AT INLET FITTINGS

1. Leakage of air into suction line at connections or valve stem
2. Cover gasket of hair and lint strainer needs cleaning
3. Low water level in pool

6 PRODUCT DIMENSIONS AND TECHNICAL PARAMETERS TABLE

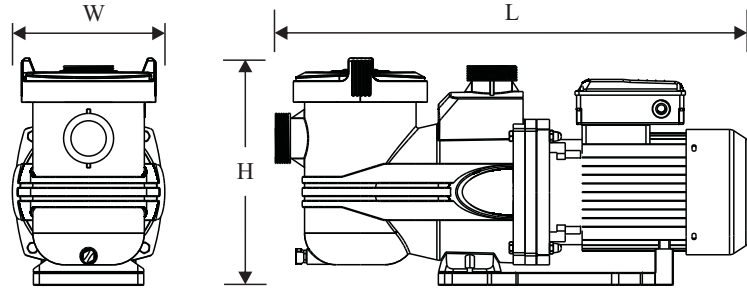

| Model | Horsepower (HP) | Rated Power (KW) | Phase | Voltage (V) | Inlet Port Dia (Inch) | Outlet Port Dia (Inch) | Length (mm) | Width (mm) | Height (mm) |
|-------------|-----------------|------------------|--------|-------------|-----------------------|------------------------|-------------|------------|-------------|
| WL-HLLF075M | 0.75 | 0.6 | Single | 220 | 1.5" | 1.5" | 595 | 200 | 295 |
| WL-HLLF100M | 1 | 0.75 | | | | | | | |
| WL-HLLF150M | 1.5 | 1.1 | | | | | | | |
| WL-HLLF200M | 2 | 1.5 | | | 605 | | | | |
| WL-HLLF300M | 3 | 2.2 | | | | | | | |
| WL-HLLF100T | 1 | 0.75 | Three | 380 | 1.5" | 1.5" | 595 | | |
| WL-HLLF150T | 1.5 | 1.1 | | | | | | | |
| WL-HLLF200T | 2 | 1.5 | | | | | 605 | | |
| WL-HLLF300T | 3 | 2.2 | | | | | | | |

7 PRODUCT PERFORMANCE CURVE

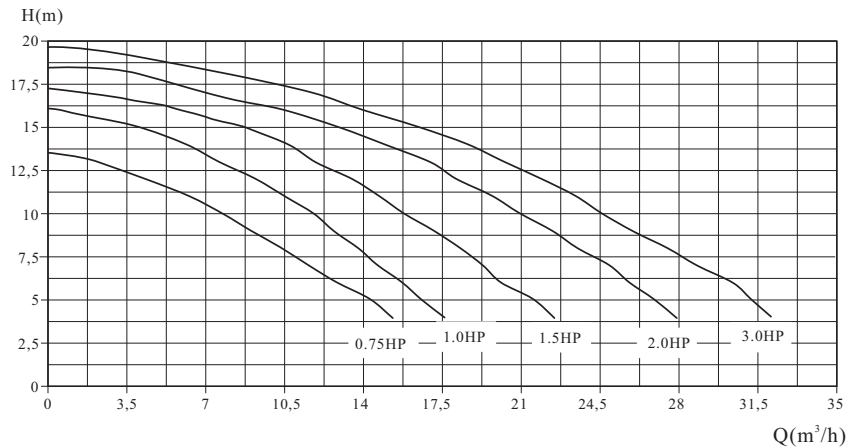

8 PRODUCT STRUCTURE

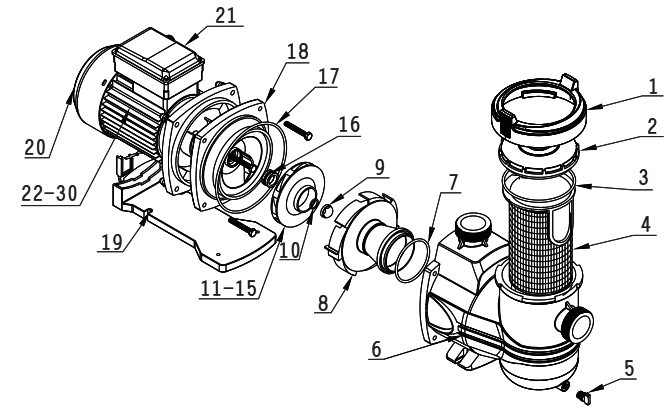

◆ Product Structure:

- | | |
|-----------------------|--------------------------------|
| 1. Trap ring lock | 16. Mechanical Seal |
| 2. Trap Cover | 17. O Ring |
| 3. O Ring | 18. Flange/Seal Plate |
| 4. Basket | 19. Base |
| 5. Drain Plug | 20. Fan Cover |
| 6. Pump Body | 21. Capacitor Box |
| 7. Diffuser O Ring | 22. 0.75 HP Single Phase Motor |
| 8. Diffuser | 23. 1.0 HP Single Phase Motor |
| 9. Impeller Nut | 24. 0.75 HP Single Phase Motor |
| 10. Impeller Nut Ring | 25. 0.75 HP Single Phase Motor |
| 11. 0.75 HP Impeller | 26. 0.75 HP Single Phase Motor |
| 12. 1.0 HP Impeller | 27. 1.0 HP Three Phase Motor |
| 13. 1.5 HP Impeller | 28. 1.5 HP Three Phase Motor |
| 14. 2.0 HP Impeller | 29. 2.0 HP Three Phase Motor |
| 15. 3.0 HP Impeller | 30. 3.0 HP Three Phase Motor |